

All the products you need for

Engineered Kitchen Ventilation Systems.

Grease Grabber™ Pollution Control Units

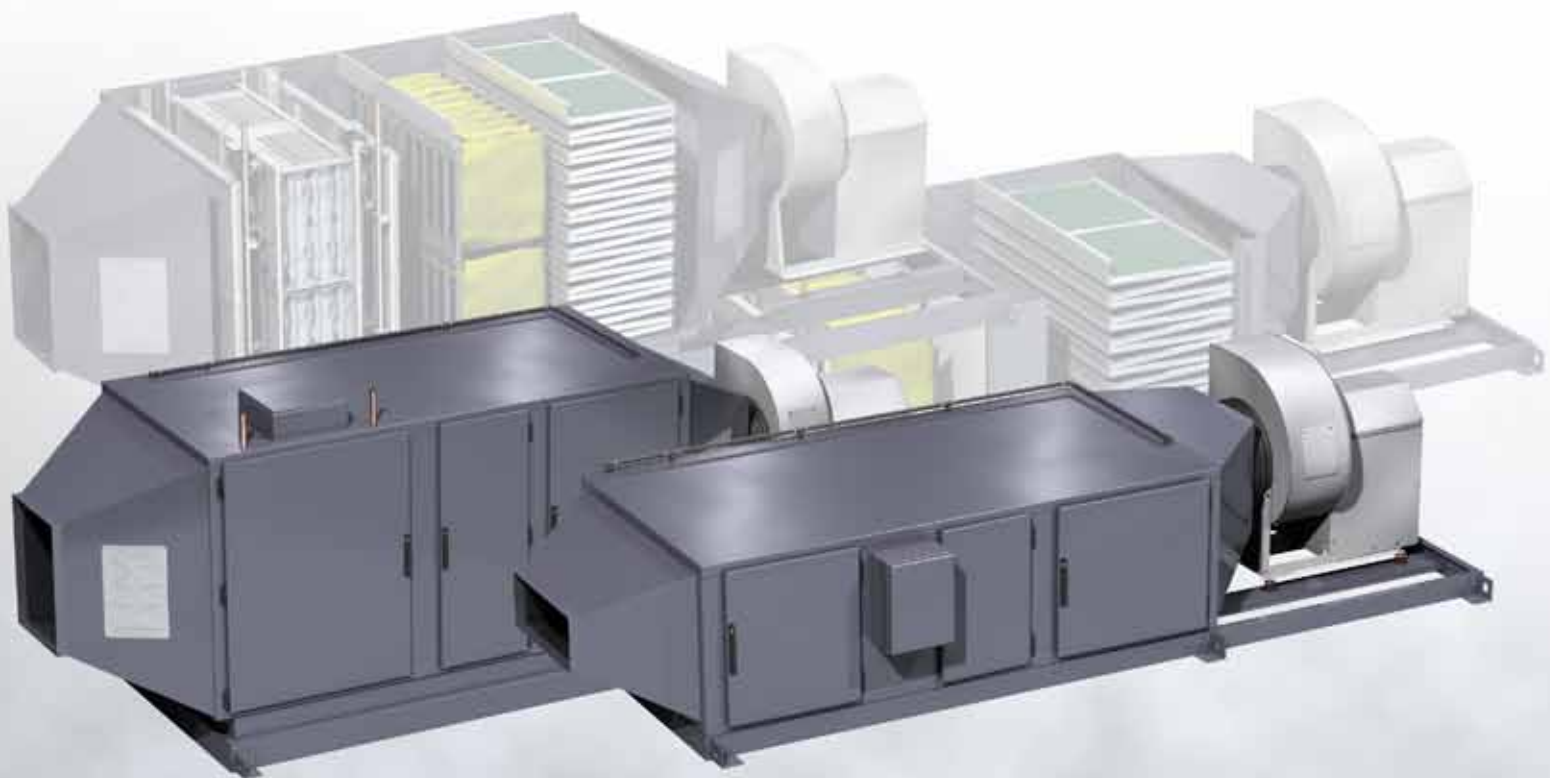

July 2011

Comfortable, energy-efficient kitchen ventilation starts here.

Accurex specializes in energy-efficient ventilation systems—for restaurants and other food service establishments. Our many top performing kitchen ventilation products reflect the industry's latest technological advances and will provide you with a fully integrated kitchen ventilation system that results in an efficient, balanced building where customers and employees prefer to dine and work.

Our state-of-the-art, computer-aided product selection program (CAPS) helps you select and configure products for your system, view real-time drawings and create AutoCAD® files quickly. You'll also like the friendly, responsive customer service we provide. Your Accurex representative is just a phone call or e-mail away, and is always well prepared to help you design a ventilation system that reduces future energy and operating costs.

We listen to you, our customer, when designing our diverse product line.

Accurex believes in continuous improvement. Our engineers are constantly developing and redesigning products, responding to the needs of our customers. Extensive prototype modeling and testing results in products that have higher efficiencies with lower installation and operating costs. Accurex engineers are focused on delivering reliable and convenient products that result in a positive ventilation experience. We proudly support green design.

Reliability and top performance are ensured through extensive testing.

Accurex products are comprehensively tested for structural integrity, aerodynamic performance, sound levels, mechanical operation, vibration, temperatures, environmental impact and more. Fans are tested in two on-site third-party registered air chambers and a registered sound testing facility. Accurex products carry several certifications as they apply including AMCA, UL, ETL, and NSF.



Even the best kitchen hood grease filters may need a little backup as no mechanical hood filter is 100% efficient at removing all forms of grease.

- Grease vapor and odors are not removed
- Odors may cause neighbor complaints
- Local ordinances/codes may require additional filtration and/or odor control

Make a *play* against grease and odor!

Accurex's Grease Grabber™ Triple Play and Power Play products are specifically designed to eliminate both smoke and grease particles from your kitchen exhaust system, and odor control modules eliminate or reduce odors to acceptable levels.



High efficiency filtration at the hood, like the Grease Grabber dual stage filtration system, is important. Capturing a greater percentage of grease at the hood will significantly reduce pollution control unit maintenance costs. For more information on Accurex's hood filtration options, please refer to www.accurex-systems.com.

Feature	Benefit
Continuously welded single piece construction on a common mounting rail	Makes installation fast and easy
Thermo-set powder painted inside/outside	Enhanced corrosion protection and sustainability
Fan motors and drives are mounted outside of the airstream, per NFPA 96	Eliminates fan motor and drive exposure to grease
Uniquely bonded activated carbon filters	Effective removal of cooking odors
Choice of Amerex or Ansul	Fully pre-piped fire protection system

Grease Grabber™ Triple Play

The Grease Grabber Triple Play uses a 3-stage mechanical filter arrangement to clean grease and smoke particles from the exhaust air at a low up front cost. Independent pressure switches signal when any of the 3 filter stages need replacing, taking the guess work out of maintaining the equipment. The Grease Grabber Triple Play incorporates activated carbon panels to remove odor molecules prior to discharging the air, reducing the impact of kitchen exhaust to the surroundings.

1 Factory inlet transition fabricated to match ductwork for ease of installation

2 MERV 8 pre-filter removes large particles from the incoming airstream to protect high efficiency filters and minimize maintenance

3 MERV 14 high capacity bag filter removes a large percentage of smaller particles not captured by the pre-filter

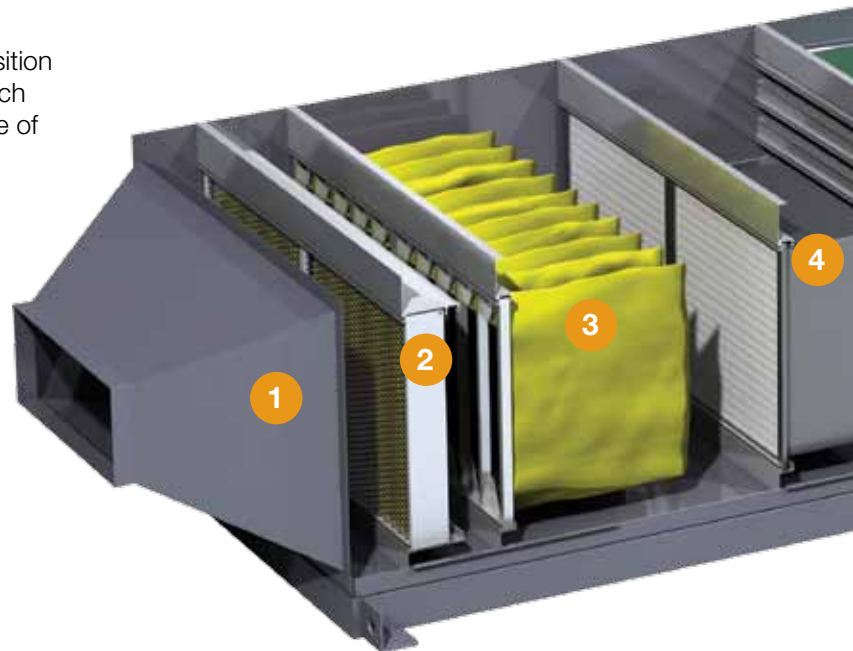

Metal framed filters in extruded aluminum and gasketed tracks prevents air from bypassing the filters.



Internal pressure switches monitor each individual filter stage. A remote filter status indicator panel advises maintenance staff when each filter stage requires replacement.



Optional Items

- MERV 17 HEPA filters available for efficiencies greater than 95%.
- Potassium permanganate and other impregnates available for code compliance and/or to deal with specific odors.
- Accurex inline fan options are available to fit specific job needs.
- Unit can be constructed in multiple sections for field assembly if required.

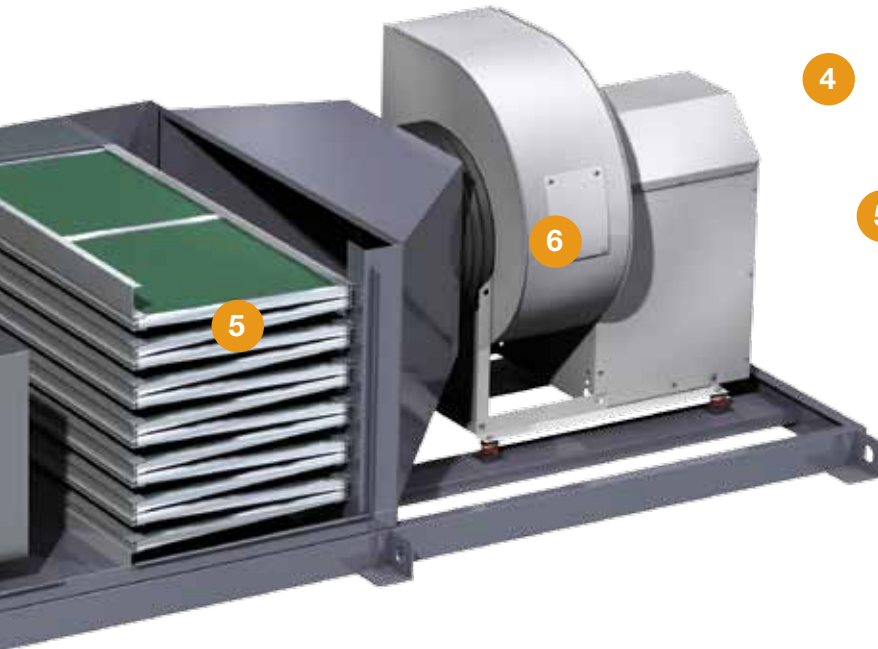

- 4 MERV 16 rigid final filter ensures a minimum overall particulate removal efficiency of 95%
- 5 Bonded activated carbon filters reduce cooking odors with a generous application of 95 lbs. of carbon per 1000 cfm of exhaust to maximize performance and minimize maintenance.
- 6 Accurex utility set fan with motor and drive mounted outside of the airstream per NFPA96. Factory provided high temperature flex fabric transition.

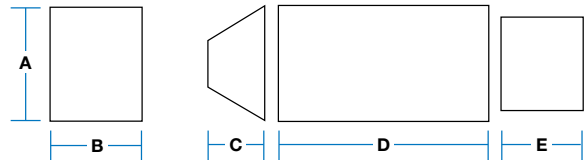

Dimensional Information

Model XPBRC	Max Air Volume ¹ (cfm)	Height (inches) A	Width ² (inches) B	Inlet Transition ³ (inches) C	Unit Length (inches) D	Outlet Trans/Fan (inches) E	Unit Weight (pounds)
-10-10	2,000	34	26.3	18-26	98	52.3	1100
-10-20	4,000	34	50.0	18-26	98	57.8	1600
-10-30	6,000	34	73.7	18-26	98	71.5	2150
-20-20	8,000	58	50.0	18-26	98	72.0	2600
-20-30	12,000	58	73.7	18-26	98	77.8	3500
-20-40	16,000	58	97.4	18-26	98	99.1	4200
-30-30	18,000	82	73.7	18-26	98	78.0	4700
-30-40	24,000	82	97.4	18-26	98	84.1	5700
-40-40	32,000	109	97.4	18-26	98	98.4	7300
-40-50	40,000	109	121.5	18-26	98	104.4	8000

1 Maximum air volume is based on 500 ft/min air velocity across the precipitator
 2 Lifting lugs for the unit add a nominal 4 inches to each side of the unit width
 3 Actual dimension based on incoming duct dimension to ensure expansion angles do not exceed 45°

NOTE: Dimensions are subject to change pending final fan selection
 NOTE: Type and volume of cooking and cooking fuel must be factored in when selecting unit. Consult factory for final selection.



Grease Grabber™ Power Play

The Grease Grabber Power Play electrostatic precipitator is the best available technology when it comes to kitchen pollution control. It provides optimum performance with low operating costs. The permanent electrostatic collector section removes grease and smoke particles from the airstream. Additionally, the integrated self cleaning sequence, initiated by the system controls, readies the Power Play to go to work again without the time and expense of replacing filters. The Power Play incorporates activated carbon panels to remove odor molecules prior to discharging the air, reducing the impact of kitchen exhaust to the surroundings.

1 Factory inlet transition fabricated to match ductwork for ease of installation

2 Aluminum mesh pre-filter removes large particles from the incoming airstream prior to reaching the ionizer cell.

3 The electrostatic collector's ionizer imparts a positive electrical charge on the grease and smoke particles as they pass. These particles are then repelled by positively charged plates and collected on negatively charged plates.

4 Aluminum mesh mist eliminator that prevents wash water from entering safety filter and carbon sections.

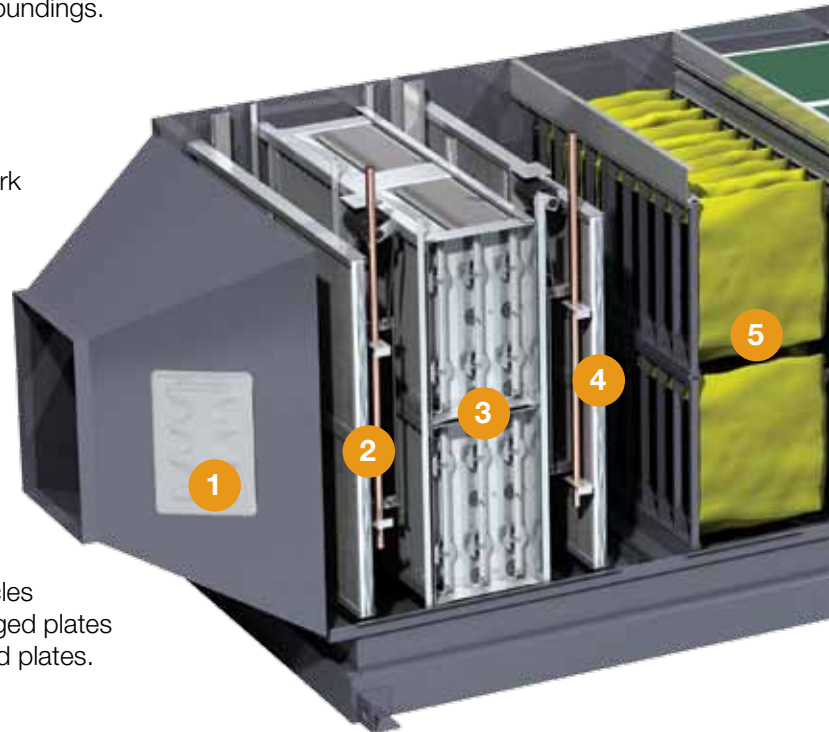

Remote mounted control panel is pre-programmed to sequence the wash cycle of the electrostatic collector section at a set schedule, minimizing manual maintenance.



Remote mounted detergent dispenser for the electrostatic collector self-cleaning system. Holds up to 55 gallons for less frequent maintenance.



Optional Items

- MERV 17 HEPA filters available for efficiencies greater than 95%.
- Potassium permanganate and other impregnates available for code compliance and/or deal with specific odors.
- Accurex inline fan options available to fit specific needs.
- Unit can be constructed in multiple sections for field assembly if required.

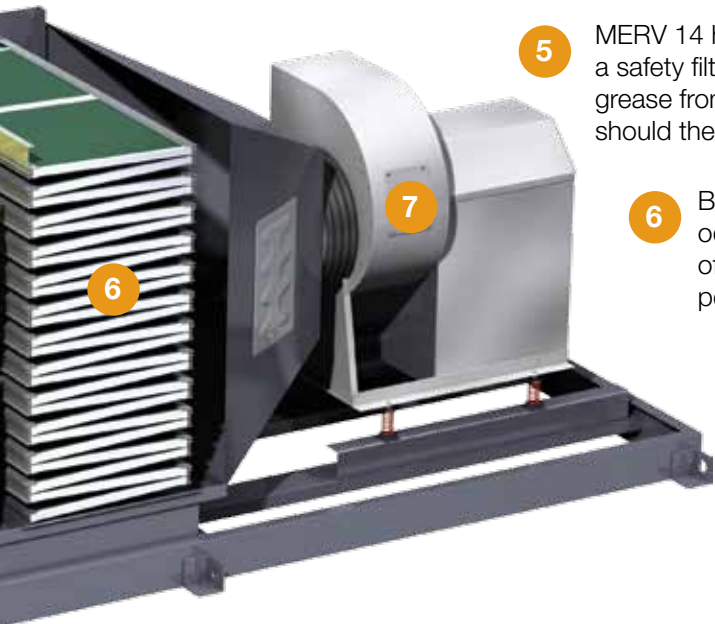

5 MERV 14 high capacity bag filter acts as a safety filter preventing high amounts of grease from saturating the carbon panels should the unit's ionizer lose power.

6 Bonded activated carbon filters reduce cooking odors with a generous application of 156 lbs. of carbon per 1000 cfm of exhaust to maximize performance and minimize maintenance.

7 Accurex utility set fan with motor and drive mounted outside of the airstream per NFPA96. Factory provided high temperature flex fabric transition.

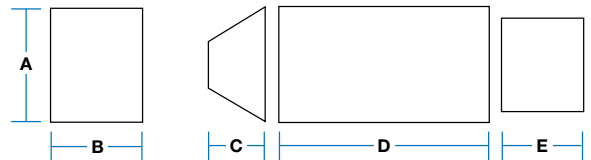

Dimensional Information

Model XSA	Max Air Volume ¹ (cfm)	Height (inches) A	Width ² (inches) B	Inlet Transition ³ (inches) C	Unit Length (inches) D	Outlet Trans/Fan (inches) E	Unit Weight (pounds)
-02-03	2,000	41	42.625	18-26	106.125	58.313	3100
-02-04	2,500	41	54.625	18-26	106.125	65.313	3620
-02-05	3,500	41	65.375	18-26	106.125	65.313	4025
-02-06	4,000	41	77.375	18-26	106.125	67.313	4280
-04-04	5,500	65	54.625	18-26	106.125	76.188	4580
-04-05	6,500	65	65.375	18-26	106.125	78.313	5200
-04-06	8,000	65	77.375	18-26	106.125	83.313	5700
-04-07	9,000	65	89.063	18-26	106.125	83.313	6420
-04-08	10,500	65	101.063	18-26	106.125	96.876	7080
-04-09	12,000	65	112.750	18-26	106.125	101.375	7560
-06-08	16,000	88.875	101.063	18-26	106.125	103.313	8800
-06-09	18,000	88.875	112.750	18-26	106.125	103.313	9510

1 Maximum air volume is based on 350 ft/min air velocity across the precipitator
 2 Lifting lugs for the unit add a nominal 4 inches to each side of the unit width
 3 Actual dimension based on incoming duct dimension to ensure expansion angles do not exceed 45°

NOTE: Dimensions are subject to change pending final fan selection
 NOTE: Type and volume of cooking and cooking fuel must be factored in when selecting unit. Consult factory for final selection.





ACCUREX
ENGINEERED RESTAURANT SYSTEMS

Warranty

Accurex warrants this equipment to be free from defects in material and workmanship for a period of one year from the purchase date. Any units or parts which prove defective during the warranty period will be replaced at our option when returned to our factory, transportation prepaid. Motors are warranted by the motor manufacturer for a period of one year. Should motors furnished by Accurex prove defective during this period, they should be returned to the nearest authorized motor service station. Accurex will not be responsible for any removal or installation costs.

As a result of our commitment to continuous improvement, Accurex reserves the right to change specifications without notice.

Accurex, LLC
P.O. Box 410 • Schofield, WI 54476
Phone: 800.333.1400 • Fax: 715.241.6191
www.accurex-systems.com

A Greenheck Company

Copyright © 2011 Accurex, LLC
Kitchen Ventilation Systems
Grease Grabber™ Pollution Control Units
01 ACX 1007 R1 7-2011