

Installation, Operation, and Maintenance Manual

Receiving

Accurex model XTIF is thoroughly inspected and test run at the factory. Items such as proper wheel alignment, balance, vibration and workmanship are analyzed by quality control personnel using state-of-the-art equipment.

However, damage may occur during handling and shipping. Therefore, it is important that the unit be carefully inspected for visible and concealed damage before beginning installation. In addition, check to see that all accessory items are present.

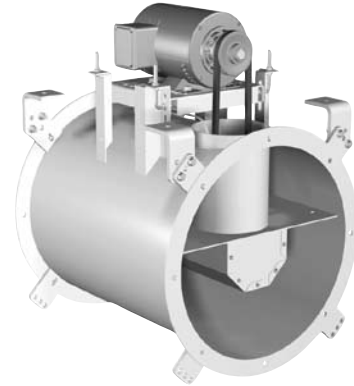

**XTIF Inline
Level 1 & 2**

REPORT ANY DAMAGED EQUIPMENT TO THE SHIPPER IMMEDIATELY!

Handling

Fans are to be moved by either the mounting brackets provided or by the skid when a forklift is used. All XTIF inline models have mounting brackets located at the ends of the fan housing from which slings can be attached (see Fig. 1).

Fans should NOT be lifted by the shaft, housing, motor, belt guard, or any other accessories.

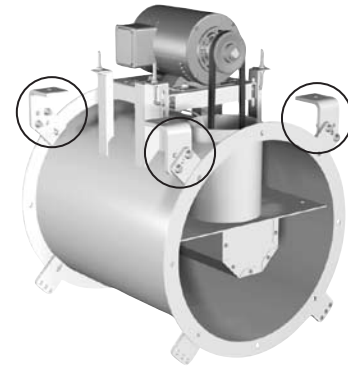

Fig. 1 - Mounting Brackets

Storage – Indoor and Outdoor

When a fan is to be stored for a period of time, it must be protected from dirt and moisture. Use of a tarp to cover the unit will aid in keeping it clean and dry, but avoid using a black plastic tarp as it will promote condensation. Improper storage which results in damage to the fan will void the warranty. If the storage period is lengthy, the wheel and motor should be rotated periodically and the bearings purged with fresh grease. In humid, dusty or corrosive environments, rotate the fan and purge the bearings once a month. Under normal conditions, this procedure should be repeated once every three months.

Please read and save these instructions for future reference. Read carefully before attempting to assemble, install, operate or maintain the unit. Failure to comply with instruction could result in personal injury and/or property damage!

Installation

Effect of Installation on Performance

Any installation with inlet or discharge configurations that deviate from these recommendations may result in reduced fan performance. Restricted or unstable flow at the fan inlet can cause pre-rotation of incoming air or even loading of the fan wheel yielding large system losses and increased sound levels. Free discharge or turbulent flow in the discharge ductwork will also result in system effect losses.

The most common inlet and discharge conditions which affect fan performance are:

Inlet Duct Turns

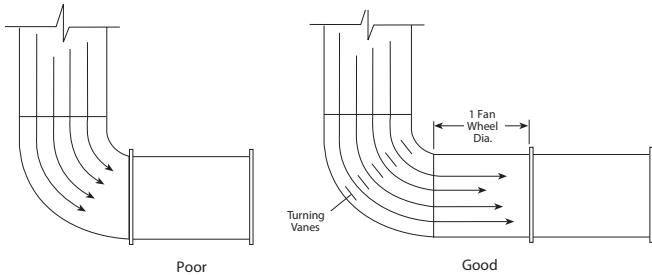

Installation of a duct turn or elbow too close to the fan inlet reduces fan performance because air is loaded unevenly into the fan wheel. To achieve full fan performance there should be at least one to two fan wheel diameters between the turn or elbow and the fan inlet.

Discharge Duct Turns

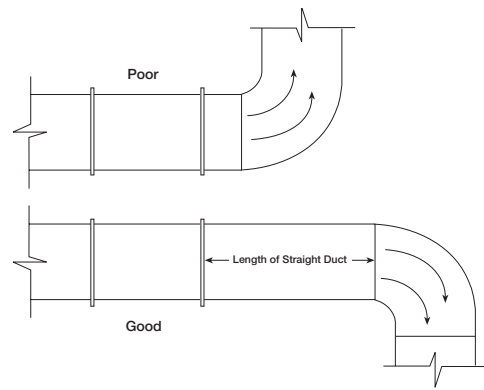

Fan performance is reduced when duct turns are made immediately off the fan discharge. To achieve cataloged fan performance, there should be at least one equivalent duct diameter of straight ductwork between the fan discharge and any duct turns.

Typical Installations

Following are typical mounting installations for model XTIF (horizontal or vertical). For horizontal XTIF's with motor in the 3 or 9 o'clock position or vertical installations, additional mounting rails are recommended. Mounting rail dimensions are shown for field fabrication.

Horizontal Ceiling Hung

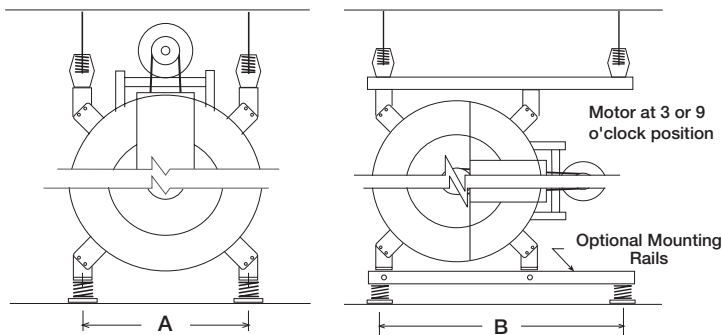

Mounting Hole Locations - Inches			
Fan Size	A	B	Depth*
9	17 1/2	26	18 3/8
10	17 1/2	26	18 3/8
12	17 1/2	26	18 3/8
13	19	28 1/2	19 3/8
16	21 3/4	33	23 3/8
18	26 1/4	37	26 3/8
22	30 1/2	44	29 5/8
24	35	50	33 1/8
30	42	56	42 3/8
36	46 3/4	62	48 1/8

*Depth dimension is the center distance between holes in the front and rear mounting brackets.

Vertical Ceiling Hung

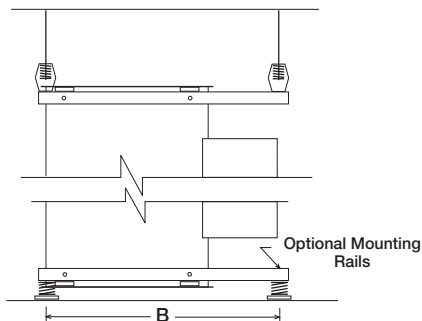

Mounting Hole Locations - Millimeters			
Fan Size	A	B	Depth*
9	445	660	467
10	445	660	467
12	445	660	467
13	483	724	505
16	552	838	606
18	667	940	670
22	775	1118	752
24	889	1270	841
30	1067	1422	1083
36	1187	1575	1222

*Depth dimension is the center distance between holes in the front and rear mounting brackets.

Supplemental Installation Practices for UL 762 Listed (Restaurant Exhaust)

This section is to provide additional information when dealing with fans used in applications involving grease laden air.

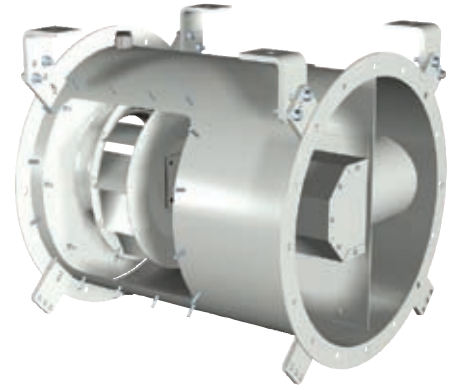

- All units used in applications with grease laden air are to be installed in accordance to NFPA 96, IMC 2203 and local codes. Consult local code authorities for your specific requirements.
- Fans shall be located in an easily accessible area of adequate size to allow for service or removal. Exhaust fans with ductwork connected to both ends shall have access for cleaning and inspection within 3 ft. (915 mm) of each end of the fan (NFPA 96).
- Maintain a minimum clearance of at least 18 inches (457 mm) to combustible material and 6 inches (152 mm) to either limited-combustible or noncombustible material (NFPA 96).
- Fans are to be installed with the motors in the 3 or 9 o'clock (C or G) positions. Motors located in this configuration may cause an unbalanced load that should be considered if isolators are to be used. Equalized loading between isolators can be achieved through the use of mounting rails.

It is recommended to install the fan near the end of the duct run. This limits the amount of positive pressure in the system. The diagram illustrates an inline fan exhausting air near the final termination point. See local codes and NFPA 96 for any restrictions and requirements for wall terminations.

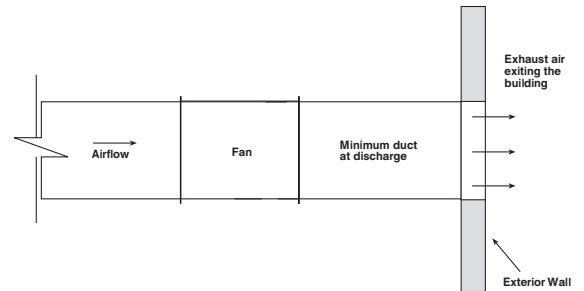

- A drain is provided for single-point drainage of water and residue. When installed correctly, one of the two housing drains will be located on the bottom. This drain is used to remove any accumulated grease and / or cleaning solutions. Some means for collection of this residue must be provided, either a container directly under the drain or use an adapter and pipe to carry the residue to a remote collection point. Remove drain plug prior to connection to grease collection device.
- Provision to open and remove the access door is required for periodic cleaning and maintenance. The access door is clearly labeled and indicates that access to this location must be maintained. Any enclosure openings required to reach the access panel shall be large enough to allow for the removal of the panel.
- Inline fans shall be connected to the exhaust duct by flanges securely bolted as shown in the figures below (NFPA 96). Flexible connectors shall not be used. Units supplied with matching companion flanges are to have this part welded to the ductwork and then bolted to the fan. Gaskets used in the over-lapping connection style shall not be positioned in a manner to have direct contact with the grease.

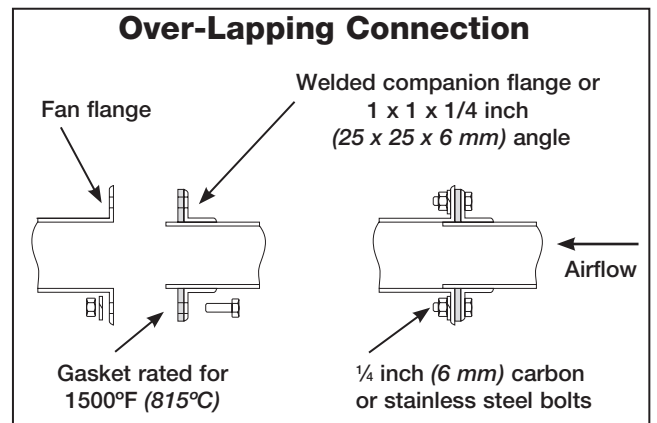
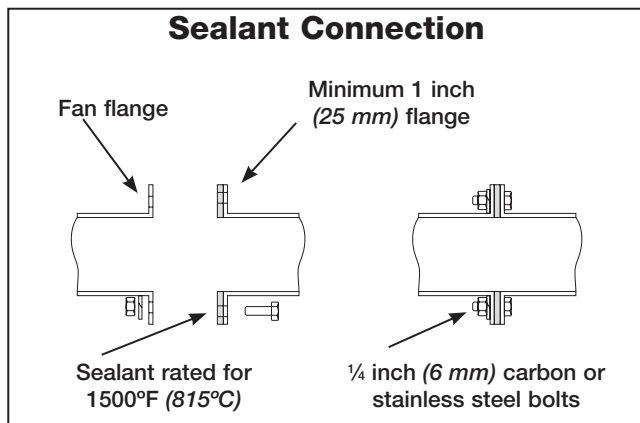

Cleaning of Internal Components

- Entire wheel should be cleaned during routine duct cleaning. Partial cleaning may result in an unbalanced wheel that can cause premature bearing failure or excessive vibration.
- Grease / cleaning solution should drain freely through the provided drain connection. Remove any obstructions inhibiting proper drainage.
- Only the access door is removed during routine duct cleaning. The bearing cover is not removed during routine cleaning. The bearing cover is removed only when inspecting or changing the bearings, fan shaft or driven pulley.

Sealant / Gasket / Seal Replacement

Fan to Duct Sealant / Gasket Replacement — Repair or replace sealant / gasket as needed. Replacement sealant or gasket shall be rated for 1500°F (815°C) and shall be grease tight such as 3M Fire Barrier 2000+ Silicone Sealant. See Sealant and Over-lapping Connection figures for proper installation.

Access Door / Bearing Cover Gasket Replacement — Replace access door or bearing cover gasket material as needed. Gasket material for the access door is 1/2 x 1/2 inch (13 x 13 mm) Accurex part number 220145. Gasket for the bearing cover is 1/8 x 1/2 inch (4 x 13 mm) Accurex part number 220144. Both items are ordered by the foot.

Mechanical Seal — A mechanical seal, located inside the bearing cover, is used to keep grease from penetrating into this area. Contact your Accurex Representative with the fan's serial number for appropriate sizing and part number for a replacement mechanical seal.

Operation

Electrical Connections

Before electrical connections are made, the supply voltage, phase and ampere capacity must be checked for compatibility with the fan motor. In addition, the supply wiring must be properly fused and conform to local and national electrical codes.

The supply wires are then connected to an optional safety disconnect switch (if supplied) or wired directly to the motor.

Pre-Start-Up Checks

1. Check all fasteners for tightness.
2. The wheel should be aligned as shown in Fig. 4. Although the wheel position is preset and the unit is test run at the factory, movement may occur during shipment.

The radial gap should be consistent at all locations between the centrifugal wheel and the inlet cone. Centering may be accomplished by loosening the inlet cone bolts and repositioning the inlet cone.

To obtain the optimum performance, the centrifugal wheel must overlap the inlet cone. Adjustments can be made by loosening the set screws in the wheel and moving the wheel to the desired position.

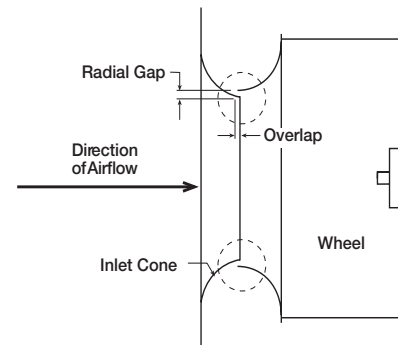

Fig. 4

3. Wheel rotation should be in the same direction as the rotation decal affixed to the unit. For 3-phase installations, fan rotation can be reversed by simply interchanging any two of the three electrical leads. For single phase installations, follow the wiring diagram located on the motor.
4. Adjustable motor pulleys are preset at the factory for the specified fan rpm. Fan speed can be increased by closing or decreased by opening the adjustable pulley. Two or three groove variable pitch pulleys must be adjusted an equal number of turns open or closed.

Note: Any increase in fan speed represents a substantial increase in horsepower required from the motor. Always check motor load amperage and compare to name plate rating when changing fan speed.

Maintenance

WARNING!

Disconnect and secure to the "OFF" position all electrical power to the fan prior to inspection or servicing. Failure to comply with this safety precaution could result in serious injury or death.

Once the fan has been put into operation, a periodic maintenance program should be set up to preserve the reliability and performance of the fan. Items to be included in this program are:

- Bearings
- Belts
- Fasteners
- Set Screws
- Motors
- Removal of Dust/Dirt

Bearings

Bearings are the most critical moving part of the fan and should be inspected at periodic intervals. Locking collars and set screws, in addition to fasteners attaching the bearing to the bearing plate, must be checked for tightness. In a clean environment and temperature above 32°F (0°C) and below 200°F (93°C), fan shaft bearings with grease fittings should be lubricated semi-annually using a high quality lithium based grease. If unusual environmental conditions exist such as temperatures below 32°F (0°C) and above 200°F (93°C), moisture or contaminants, more frequent lubrication is required.

See bearing manufacturer's instructions or label on the fan house for lubrication schedule. Lubricate bearings with high temperature grease conforming to NLGI Grade 2, such as Mobil Mobilith SHC 100 or 200.

With the unit running, add grease very slowly with a manual grease gun until a slight bead of grease forms at the seal. Be careful not to unseat the seal by over lubricating or using excessive pressure. Bearings without grease fittings are lubricated for life.

Belts

Premature belt failures are frequently caused by improper belt tension (either too tight or too loose) or misaligned pulleys. The proper tension for operating a V-belt is the lowest tension at which the belts will not slip at peak load conditions. For initial tensioning, the proper belt deflection half-way between pulley centers is 1/64 in. for each inch of belt span. For example, if the belt span is 64 inches, the belt deflection should be one inch using moderate thumb pressure at midpoint of the drive. (see Fig. 5).

Check belt tension two times during the first 24 hours of operation and periodically thereafter. To adjust belt tension, simply pivot the motor on the motor plate. Use the bolts in the slotted brackets and adjustment rods with bolts as adjustment points until proper belt tension is attained.

It is very important that the drive pulleys remain in proper alignment after adjustments are made. Misalignment of pulleys will result in premature belt wear, noise, vibration and power loss. (see Fig. 6).

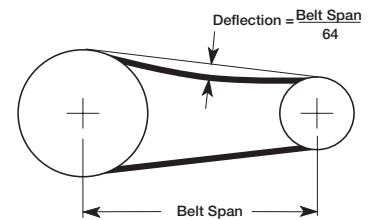

Fig. 5

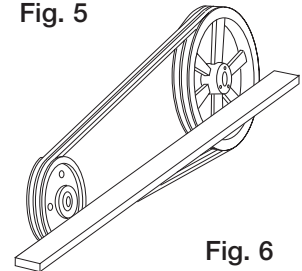

Fig. 6

Fasteners and Set Screws

A periodic inspection should include checking all fasteners and set screws for tightness. Particular attention should be paid to set screws attaching the propeller to the shaft and the shaft to the bearings. Loose bearing set screws will lead to premature failure of the fan shaft.

Motors

Many fractional horsepower motors installed on the smaller fans are lubricated for life and require no further attention. Motors supplied with grease fittings should be greased according to directions printed on the motor.

Removal of Dust and Dirt

Dirt clogs cooling vents on the motor housing, contaminates bearing lubricant, and collects on the impeller causing severe imbalance if left unchecked. The exterior surface of the motor and impeller should be thoroughly cleaned periodically. Use caution and do not allow water or solvents to enter the motor or bearings. Under no circumstances should motors or bearings be sprayed with steam or water.

Parts List

Each fan bears a manufacturer's nameplate with model number and serial number embossed. This information in addition to the parts list shown will assist the local Accurex representative and the factory in providing service and replacement parts.

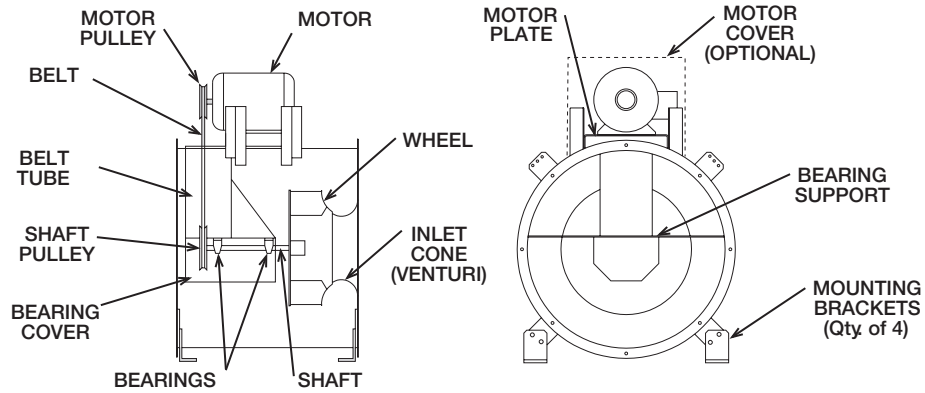

WARRANTY

Accurex warrants this equipment to be free from defects in material and workmanship for a period of one year from the date of purchase. Any units or parts which prove to be defective during the warranty period will be replaced at our option when returned to our factory, transportation prepaid. Motors are warranted by the motor manufacturer for a period of one year. Should motors furnished by Accurex prove defective during this period, they should be returned to the nearest authorized motor service station. Accurex will not be responsible for any removal or installation costs.

As a result of our commitment to continuous improvement, Accurex reserves the right to change specifications without notice.

