

Installation, Operation, and Maintenance Manual

Installation

Move fan to desired location and fasten securely through mounting holes in base. Shims may be necessary depending upon roofing material thickness. The diagram below shows dimensions for Model XRUD.

Access to the motor compartment is accomplished by removing the screws designated "R" in the drawing below. The cover can then be removed and placed on a flat surface in an area protected from strong winds that could blow it off the roof.

The voltage rating of the motor must be checked for compatibility to supply voltage prior to final electrical connection. For NFPA - restaurant applications, the electrical supply must enter the motor compartment through the breather tube. For other non-flammable applications, the electrical supply can be routed through the conduit chase between the curb cap and the bottom of the motor compartment. **Consult local code authorities for your specific requirements.**

IMPORTANT: UL/cUL 762 Installations are for Restaurant Applications.

A, B, and C motor RPMs are only approved for this installation. All must include the suffix "G".

A drain trough is provided on all XRUD fans for one point drainage of residue. Some means of collection of this residue must be provided by either placing a container directly under the trough or by utilizing an adapter to direct the residue to another location.

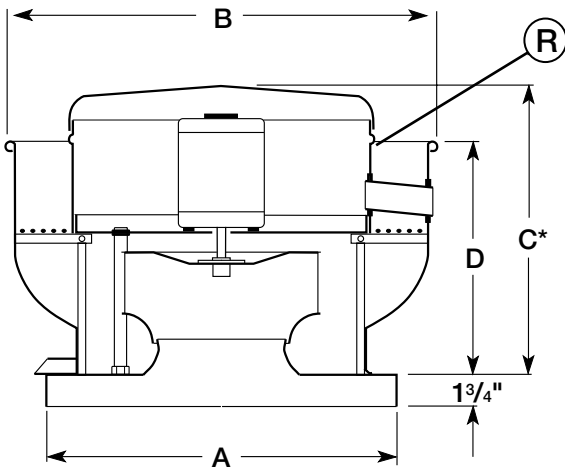

Dimensional Data

Model	A	B	C	D	Damper	Roof Opening	Approx. Unit Wt.
XRUD-060,065,070,075	17	18 ³ / ₈	13 ¹ / ₂	11 ³ / ₈	8x8	10 ¹ / ₂ x10 ¹ / ₂	26
XRUD-080,085,090	19	21	13 ³ / ₈	11 ¹ / ₂	10x10	12 ¹ / ₂ x12 ¹ / ₂	33
XRUD-095	19	21	15 ¹ / ₄	13 ⁷ / ₁₆	10x10	12 ¹ / ₂ x12 ¹ / ₂	36
XRUD-098,101,121,131	19	24 ⁷ / ₈	23 ³ / ₄	17 ³ / ₈	12x12	14 ¹ / ₂ x14 ¹ / ₂	67
XRUD-141,161	22	28 ⁷ / ₈	24 ³ / ₄	19 ³ / ₈	16x16	18 ¹ / ₂ x18 ¹ / ₂	85

Dimension "A" is the inside dimension of the curb cap. The roof curb should be 1-1/2" less than the curb cap to allow for roofing and flashing.

*May vary depending on motor size.

Pre-Starting Checks

Check all fasteners for tightness. The wheel should rotate freely and be aligned as shown at right. Wheel position is preset and the unit tested at the factory. However, movement may occur during shipment, and realignment

may be necessary. Centering (height alignment) may be accomplished by loosening the set screws in the wheel and moving the wheel to desired position.

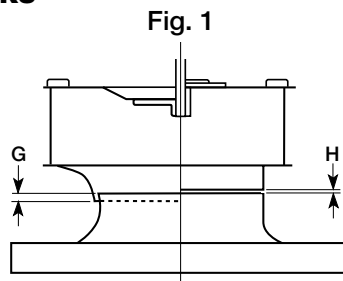

MODEL	G	H
060-095	-	3/32 in.
098-161	1/4 in.	-

Wheel Rotation

Direction of rotation is very critical. Improper rotation will result in loss of performance, excessive horsepower and possible motor burnout. Check rotation by energizing the unit only momentarily. The rotation should be as shown in the diagram at right and should be in the same direction as the rotation decals affixed to the unit.

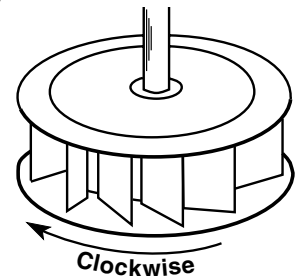

Please read and save these instructions for future reference. Read carefully before attempting to assemble, install, operate or maintain the unit. Failure to comply with instruction could result in personal injury and/or property damage!

Upon receiving unit, check for any damage that may have occurred during transit and report it immediately to the shipper. Also check to see that all accessory items are accounted for.

Maintenance

Motor maintenance is generally limited to cleaning and lubrication (where applicable). Cleaning should be limited to exterior surfaces only. Removing dust buildup on motor housing ensures proper motor cooling. Greasing of motors is only intended when fittings are provided. Many fractional motors are permanently lubricated and should not be lubricated after installation. Motors supplied with grease fittings should be greased in accordance with manufacturers' recommendations. With motor temperatures under 104°F (40°C), the grease should be replaced after 2000 hours of running time as a general rule.

Wheels require very little attention when moving clean air. Occasionally, oil and dust may accumulate causing imbalance. When this occurs, the wheel and housing should be cleaned to ensure smooth and safe operation.

All fasteners should be checked for tightness each time maintenance checks are performed prior to restarting unit.

A proper maintenance program will help these units deliver years of dependable service.

Troubleshooting

PROBLEM	CAUSE	CORRECTIVE ACTION
REDUCED AIRFLOW	System resistance too high.	Check system: Proper operation of backdraft or control dampers, obstruction in ductwork, etc.
	Unit running backwards.	Correct as shown in Fig. 2.
	Excessive dirt buildup on wheel.	Clean wheel.
	Improper wheel alignment.	See Fig. 1 and Pre-Starting Checks.
EXCESSIVE NOISE OR VIBRATION	Wheel improperly aligned and rubbing.	See Fig. 1 and Pre-Starting Checks.
	Foreign objects in wheel or housing.	Remove objects, check for damage.
	Unbalance of wheel caused by excessive dirt and grease buildup.	Remove buildup.

NOTE: Before taking any corrective action, make certain unit is not capable of operation during repairs.

Replacement Parts

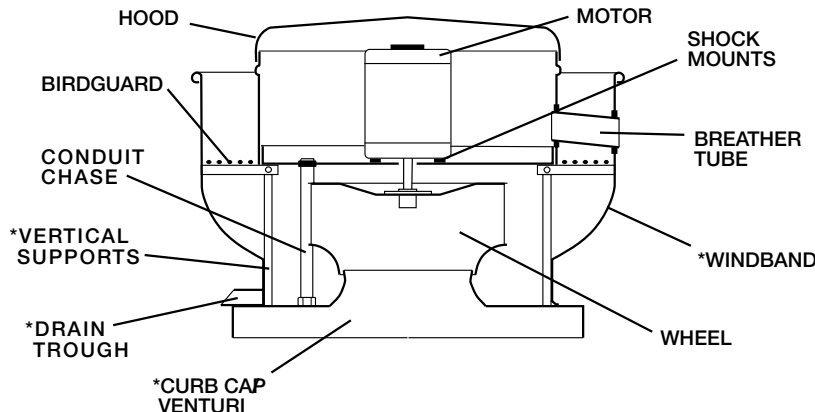

*For replacement, the windband, vertical supports, drain trough and curb cap/venturi come as one complete assembly.

NOTE

Each fan bears a manufacturer's nameplate with model number and serial number embossed. This information will assist the local Accurex representative and the factory in providing service and replacement parts.

WARRANTY

Accurex warrants this equipment to be free from defects in material and workmanship for a period of one year from the date of purchase. Any units or parts which prove to be defective during the warranty period will be replaced at our option when returned to our factory, transportation prepaid. Motors are warranted by the motor manufacturer for a period of one year. Should motors furnished by Accurex prove defective during this period, they should be returned to the nearest authorized motor service station. Accurex will not be responsible for any removal or installation costs.

As a result of our commitment to continuous improvement, Accurex reserves the right to change specifications without notice.

