

Installation, Operation, and Maintenance Manual

Securely fasten fan through mounting holes in base. Shims may be necessary depending upon roofing material thickness. Diagram below shows dimensions.

Access to motor compartment is accomplished by removing screws designated "R" in Fig. 1. Cover can be removed and placed on a flat surface in an area protected from strong winds.

Motor's amperage and voltage rating must be checked for compatibility to supply voltage prior to final electrical connection. For NFPA - restaurant applications, electrical supply must enter motor compartment through breather tube. **Consult local code authorities for specific requirements.**

A drain trough is standard on all XRUBS fans for single-point drainage of water and residue. Some means for collection of residue must be provided, either a container directly under trough or an adapter and pipe to carry residue to a remote collection point. An optional grease trap with water separator baffle is available from your Accurex representative.

A clean-out port and hinging curb cap are also provided on all XRUBS's. They aid the cleaning process through additional access to the wheel. The XRUBS is designed for the worst cooking conditions, such as char broilers, solid fuel cooking, or Oriental cooking. Fig. 2 shows a suggested Exhaust system Inspection Schedule published in NPFA 96.

Clean Out Port

Position clean out port so it is on the side of unit when hinged open, see Fig. 3.

Hinged Curb Cap

During installation of the hinge curb cap kit it is important not to allow the fan to go beyond 90¼, see Fig. 4.

Dimensional Data

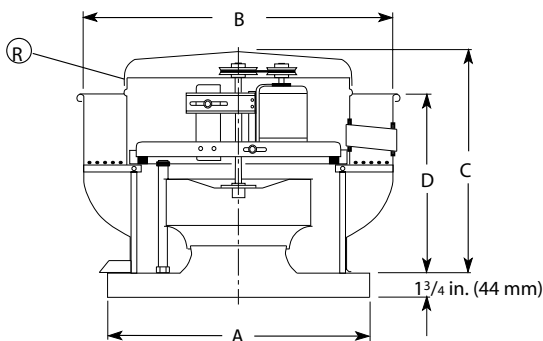
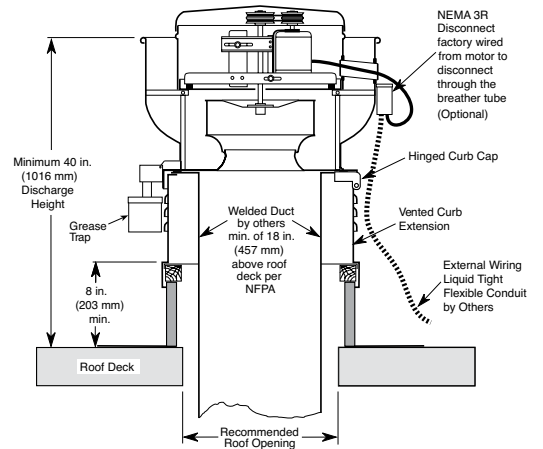

Fig. 1

Recommended Commercial Kitchen

(Traditional External Grease Drain)



Type or Volume of Cooking	Frequency Check
• Systems serving solid fuel cooking operations	Monthly
• Systems serving high-volume cooking operations, such as 24-hour cooking, charbroiling, or work cooking	Quarterly
• Systems serving moderate-volume cooking operation	Semiannually
• Systems serving low-volume cooking operations, such as churches, day camps, seasonal business, or senior centers	Annually

Fig. 2



Fig. 3



Fig. 4

Model	A	B	*C	D	Roof Opening	*Approx. Weight
XRUBS-140, 140HP	26	28 ⁷ / ₈	29 ³ / ₄	19 ³ / ₈	18 ¹ / ₂ x 18 ¹ / ₂	125 lb.
XRUBS-160, 160HP, 160XP	(660)	(733)	(756)	(492)	(470 x 470)	131 lb.
XRUBS-180, 180HP	30	35 ³ / ₈	28 ⁵ / ₈	21	20 ¹ / ₂ x 20 ¹ / ₂	190 lb.
XRUBS-200, 200HP	(762)	(899)	(727)	(533)	(521 x 521)	213 lb.

Dimension "A" is the inside dimension of the curb cap. The roof curb should be 1½ inch (38 mm) less than curb cap to allow for roofing and flashing. All dimensions are in inches (millimeters). *May vary depending on motor size.

Please read and save these instructions for future reference. Read carefully before attempting to assemble, install, operate or maintain the unit. Failure to comply with instruction could result in personal injury and/or property damage!

Upon receiving unit, check for any damage that may have occurred during transit and report it immediately to the shipper. Also check to see that all accessory items are accounted for.

Pre-Starting Checks

Check all fasteners for tightness. The wheel should rotate freely and be aligned as shown in Fig. 5. Wheel position is preset and the unit is test run at the factory. Movement may occur during shipment, and realignment may be necessary. Centering can be accomplished by loosening the bolts holding the drive frame to the shock mounts and repositioning the drive frame. Wheel and inlet cone overlap can be adjusted by loosening the set screws in the wheel and moving the wheel to the desired position.

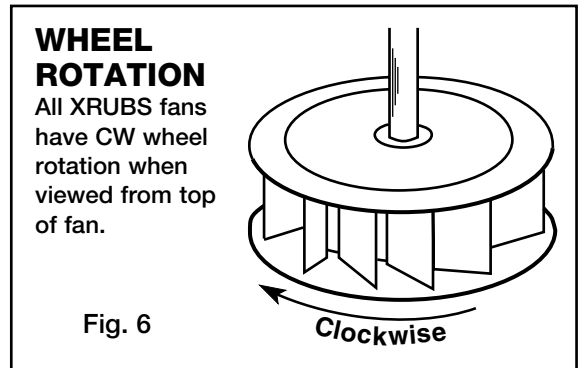
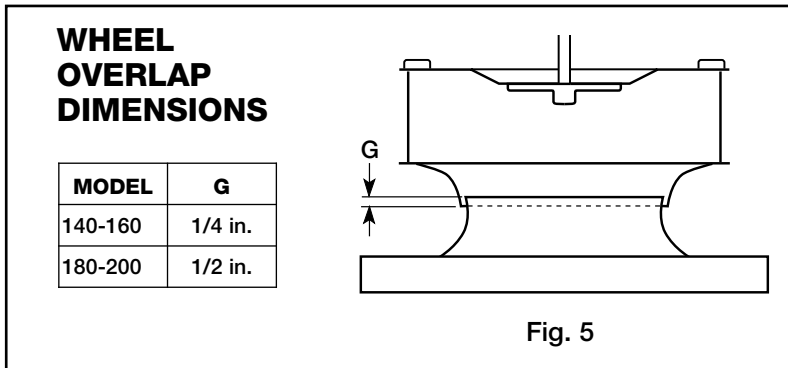

Direction of wheel rotation is critical. Reversed rotation will result in poor air performance, motor overloading and possible burnout. Check wheel rotation (viewing from the shaft side) by momentarily energizing the unit. Rotation should be clockwise as shown in Fig. 6 and correspond to the rotation decal on the unit.

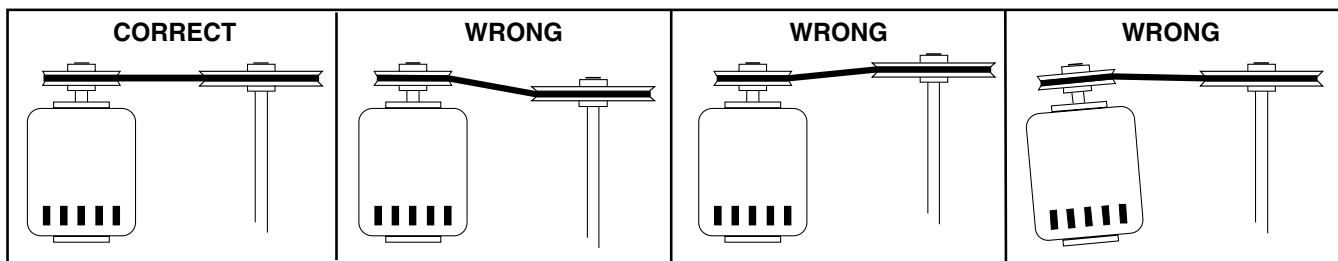
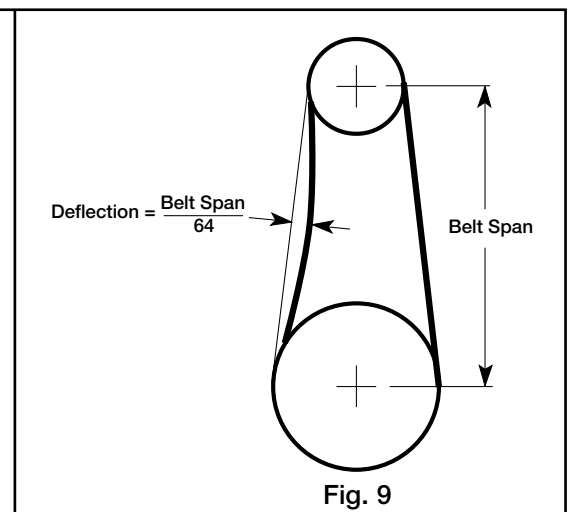
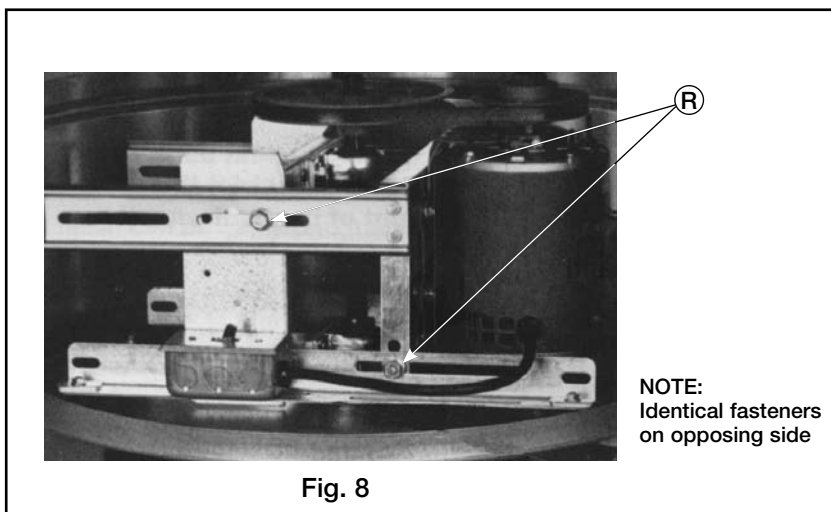

Fig. 7

If adjustments are made, it is very important to check the pulleys for proper alignment. Misaligned pulleys lead to excessive belt wear, vibration, noise and power loss. (See Fig. 7)

For all XRUBS units belt tension can be adjusted by loosening four fasteners (marked "R") on the drive frame. The motor plate slides on the slotted adjusting arms and drive frame angles in the same manner (see Fig. 8). Belt tension should be adjusted to allow 1/64 in. of deflection per inch of belt span. For example, a 15 in. belt span should have 15/64 in. (or about 1/4 in.) of deflection with moderate thumb pressure at mid-point between pulleys. (See Fig. 9). Overtightening will cause excessive bearing wear and noise. Too little tension will cause slippage at startup and uneven wear.



The adjustable motor pulley is factory set for the RPM specified. Speed can be increased by closing or decreased by opening the adjustable motor sheave. Two groove variable pitch pulleys must be adjusted an equal number of turns open or closed. Any increase in speed represents a substantial increase in the horsepower required by a unit. Motor amperage should always be checked to avoid serious damage to the motor when speed is varied.

MAINTENANCE

Belts tend to stretch after a period of time. They should be checked periodically for wear and tightness. When replacing belts, use the same type as supplied with the unit. Matched belts should always be used on units with multigroove pulleys. For belt replacement, loosen the tensioning device far enough to allow removal of the belt by hand. Do not force belts on or off. This may cause cords to break, leading to premature belt failure. Once installed, adjust belts as shown in “Pre-Starting Checks” on page 2.

Shaft bearings can be classified in two groups: relubricating and non-relubricating. All bearings on Model XRUBS fans are factory lubricated and require no further lubrication under normal use (between -20°F (-29°C) and 180°F (82°C) in a relatively clean environment). Units installed in hot, humid or dirty locations should be equipped with special bearings. These bearings will require frequent lubrication. Caution should be taken to prevent overpacking or contamination. Grease fittings should be wiped clean. The unit should be in operation while lubricating. Extreme care should be used around moving parts. Grease should be pumped in very slowly until a slight bead forms around the seal. A high grade lithium base grease is recommended.

The unit should be made non functional when cleaning the wheel or housing (fuses removed, disconnect locked off, etc.).

Motor maintenance is generally limited to cleaning and lubrication (where applicable). Cleaning should be limited to exterior surfaces only. Removing dust buildup on motor housing ensures proper motor cooling. Greasing of motors is only intended when fittings are provided. Many fractional motors are permanently lubricated and should not be lubricated further. Motors supplied with grease fittings should be greased in accordance with manufacturers’ recommendations. Where motor temperatures do not exceed 104°F (40°C), the grease should be replaced after 2000 hours of running time as a general rule.

Wheels require strong attention when moving air in grease applications. Grease, oil and dust may accumulate causing an imbalance. When this occurs, the wheel and housing should be cleaned to ensure smooth and safe operation.

All fasteners should be checked for tightness each time maintenance checks are performed prior to restarting unit.

A proper maintenance program will help these units deliver years of dependable service.

TROUBLESHOOTING

PROBLEM	CAUSE	CORRECTIVE ACTION
Reduced airflow	System resistance too high	Check system: obstructions in ductwork.
	Unit running backwards	Correct as shown in Fig. 6.
	Excessive grease buildup on wheels	Clean wheel.
	Improper wheel alignment	Center wheel on inlets.
	Bad bearings	Replace.
	Belts too tight or too loose	Refer to Fig. 9 and adjust tension.
Excessive noise or vibration	Wheel improperly aligned and rubbing	Center wheel on inlets. See Fig. 5.
	Loose drive or motor pulleys	Align and tighten. See “Pre-Starting Checks” on page 2.
	Foreign objects in wheel or housing	Remove objects, check for damage or unbalance.
	Unbalance of wheel caused by excessive dirt and grease buildup	Remove buildup.

NOTE: Before taking any corrective action, make certain unit is not capable of operation during repairs.

PARTS LIST

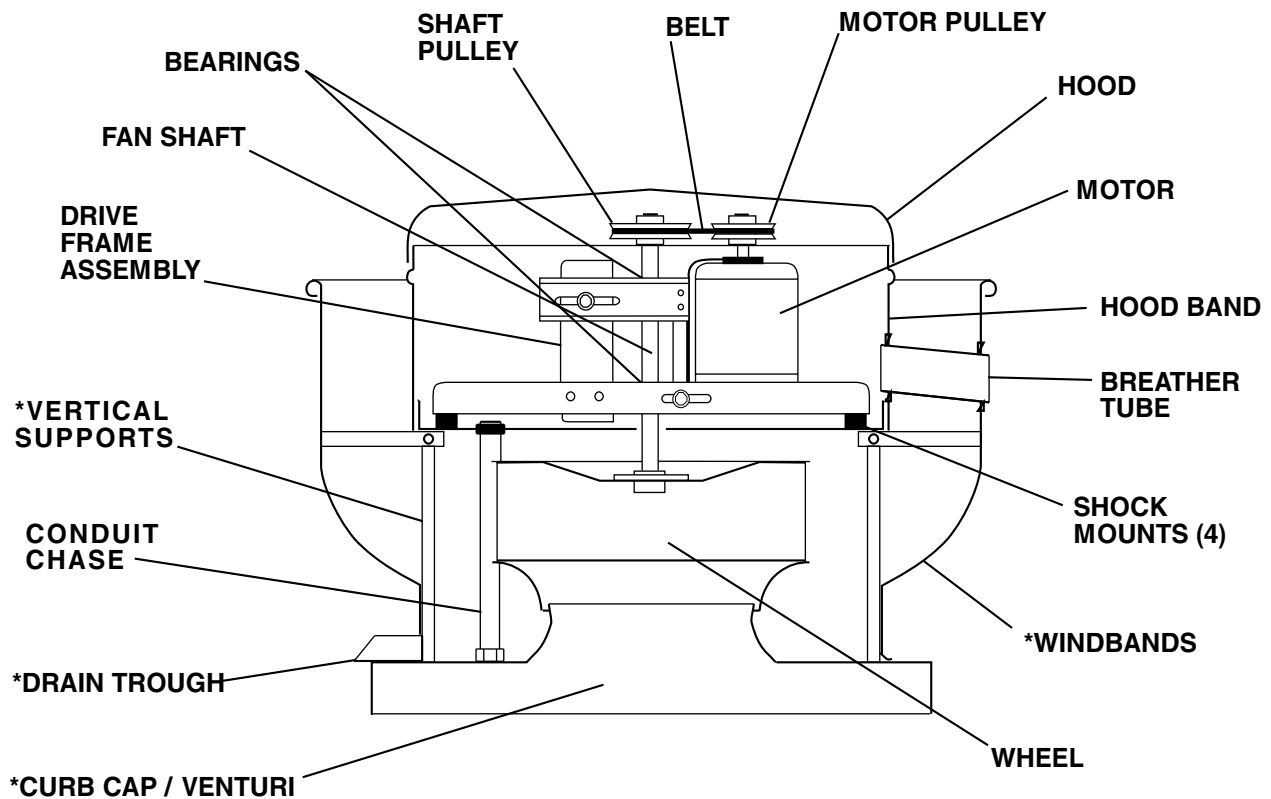

* For replacement, the windband, vertical supports, drain trough and curb cap/venturi come as one complete assembly.

NOTE: Each fan bears a manufacturer's nameplate with model number and serial number embossed. This information will assist the local Accurex representative and the factory in providing service and replacement parts.

WARRANTY

Accurex warrants this equipment to be free from defects in material and workmanship for a period of one year from the date of purchase. Any units or parts which prove to be defective during the warranty period will be replaced at our option when returned to our factory, transportation prepaid. Motors are warranted by the motor manufacturer for a period of one year. Should motors furnished by Accurex prove defective during this period, they should be returned to the nearest authorized motor service station. Accurex will not be responsible for any removal or installation costs.

As a result of our commitment to continuous improvement, Accurex reserves the right to change specifications without notice.



ENGINEERED RESTAURANT SYSTEMS

P.O. Box 410 Schofield, WI 54476
Phone: 888.333.1400 Fax: 715.241.6191
www.accurex-systems.com

IOM XRUBS Rev. 1 June 2007
Copyright © 2007 Accurex