

Installation, Operation, and Maintenance Manual

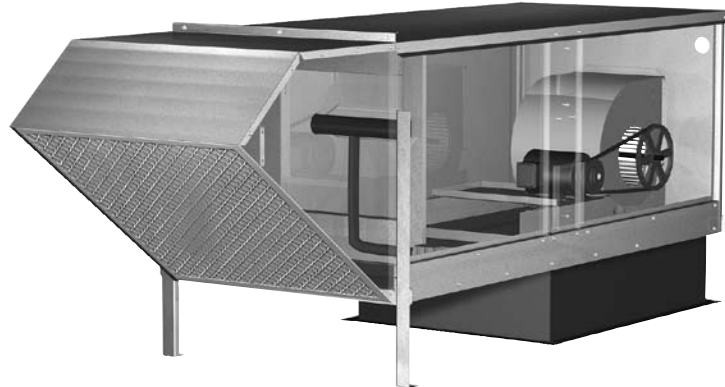

FOR YOUR SAFETY

If you smell gas

1. Open windows
2. Don't touch electrical switches
3. Extinguish any open flames
4. Immediately call your gas supplier

FOR YOUR SAFETY

The use and storage of gasoline or other flammable vapors and liquids in open containers in the vicinity of this appliance is hazardous.

Disconnect all electrical power to the fan and secure to the "OFF" position prior to inspection or servicing. Failure to comply with this safety precaution could result in serious injury or death.

WARNING!

Improper installation, adjustment, alteration, service or maintenance can cause property damage, injury or death. Read the installation, operating, and maintenance instructions thoroughly before installing or servicing this equipment.

IMPORTANT!

All factory provided lifting lugs must be used when lifting any unit. Failure to comply with this safety precaution could result in property damage, serious injury or death.

Report any damaged equipment to the shipper immediately!

All units are shipped on a skid or packaged to minimize damage during shipment. The transporting carrier has the responsibility of delivering all items in their original condition as received from Accurex. The individual receiving the equipment is responsible for inspecting the unit for obvious or hidden damage, recording any damage on the bill of lading before acceptance and filing a claim (if required) with the final carrier. Some accessory items are stored inside the unit during shipping. Care must be taken during installation to prevent damage to units.

Please read and save these instructions for future reference. Read carefully before attempting to assemble, install, operate or maintain the unit. Failure to comply with instruction could result in personal injury and/or property damage!

Upon receiving unit, check for any damage that may have occurred during transit and report it immediately to the shipper. Also check to see that all accessory items are accounted for.

Table of Contents

<p>I Installation</p> <ul style="list-style-type: none"> Clearances to Combustibles & Services Clearances 2 Unit — Arrangement DB/HZ 3 Electrical Wiring 4 Direct Gas Piping 5-6 	<p>M Maintenance</p> <ul style="list-style-type: none"> Routine 16-17 Fall 17 Maintenance Log 18 Start-up Check List 18
<p>S Start-Up</p> <ul style="list-style-type: none"> Blower 7-8 Direct Gas 9-13 	<p>M Reference</p> <ul style="list-style-type: none"> Gas Train Layout 19
<p>T Troubleshooting</p> <ul style="list-style-type: none"> Blower 13 Heater 13-14 Vibration 15 	

STORAGE

When a unit is not going to be in service for an extended period of time, certain procedures should be followed to keep the unit in proper operating condition:

- Plug all piping
- Rotate fan wheel monthly.
- Energize fan motor once every three months
- Store belts flat to keep them from warping and stretching
- Store unit in location without vibration
- Cover unit with tarp to protect from dirt and moisture

NOTE!

Do not cover unit with a black tarp, this would promote condensation.

NOTE!

Improper storage which results in damage to the unit will void the warranty.

Clearance to Combustibles / Service Clearances

	Floor	Top	Sides	Ends
Insulated Units	0 inches (0 mm)	0 inches (0 mm)	0 inches (0 mm)	0 inches (0 mm)

Clearance to combustibles is defined as the minimum distance required between the heater and adjacent combustible surfaces to ensure the adjacent surface's temperature does not exceed 90 degrees above the ambient temperature.

Recommended Minimum Service Clearances	
Housing 32 and less	42 inches (1066.8 mm) on the controls side of the unit

Clearances for component removal may be greater than the service clearances listed.

Installation - Arrangement DB / HZ

Step 1 Install Curb or Equipment Support(s)

Position curb/equipment support(s) on the roof (reference the CAPS submittal for placement of curb/equipment support(s) in relation to the unit). Verify that unit supports are level, shim if necessary. Attach curb to roof and flash into place. Attach the equipment support(s) to the roof, remove metal cover, flash to wooden nailer and reinstall cover. Refer to roof curb detail.

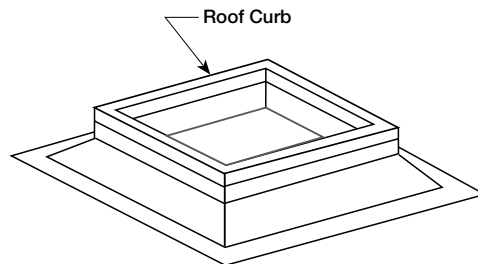

Roof Curb Detail

NOTE!

The use of a duct adapter is recommended on a downblast (DB) arrangement to align the ductwork with the supply unit. The duct adapter is only a guide and is not to be used as support for the ductwork.

Step 2 Install Ductwork

Good duct practices should be followed for all ductwork. All ductwork should be installed in accordance with SMACNA and AMCA guidelines, NFPA 96 and all local codes.

Model	Duct Size (A x B)
XDGK-109-H15	13 x 14 (330 x 356)
XDGK-110-H15	14 x 16 (356 x 406)
XDGK-112-H15	16 x 18 (406 x 457)

All dimensions shown are in inches (mm)

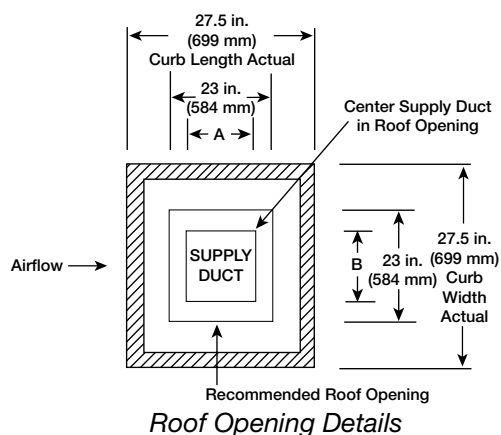

Roof Opening Details

Step 3 Apply Sealant

Apply an appropriate sealant around the perimeter of the curb to isolate fan vibration and prevent water penetration.

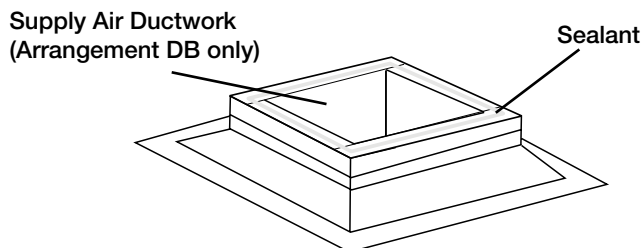

Ductwork and Sealant Application

Step 4 Install Unit

Use a crane and a set of spreader bars hooked to the factory lifting lugs to lift and center the unit on the curb/equipment support(s). Prior to disconnecting from crane, adjust support legs on the intake of the unit.

Use self-tapping sheet metal screws to fasten the unit to the curb/equipment support(s).

NOTE!

The use of all lifting lugs and a set of spreader bars is mandatory when lifting the unit.

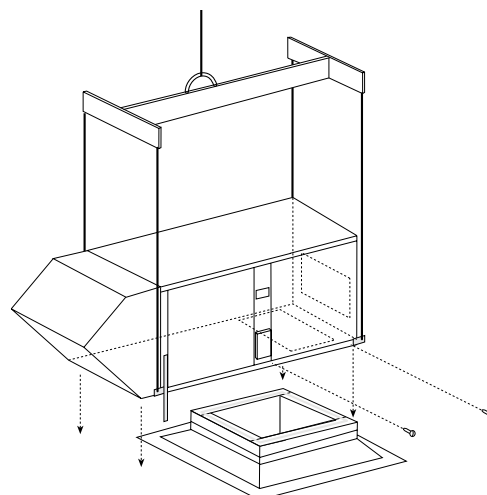

Placement of Unit

Installation - Electrical Wiring

IMPORTANT!

Before connecting power to the unit, read and understand the following instructions and wiring diagrams. Complete wiring diagrams are attached to the inside of the control center door(s).

IMPORTANT!

All wiring should be done in accordance with the latest edition of the National Electrical Code ANSI/NFPA-70 and any local codes that may apply. In Canada, wiring should be done in accordance with the Canadian Electrical Code.

CAUTION!

If replacement wire is required, it must have a temperature rating of at least 105°C, except for energy cut-off or sensor lead wire which must be rated to 150°C.

IMPORTANT!

The equipment must be properly grounded. Any wiring running through the unit in the airstream must be protected by metal conduit, metal clad cable or raceways.

DANGER!

High voltage electrical input is needed for this equipment. This work should be performed by a qualified electrician.

CAUTION!

Any wiring deviations may result in personal injury or property damage. Accurex is not responsible for any damage to, or failure of the unit caused by incorrect final wiring.

Step 1 Determine the Size of the Main Power Lines

The unit nameplate states the voltage and the unit's total MCA. The main power lines to the unit should be sized accordingly. The nameplate is located on the outside of the unit on the control panel side.

Step 2 Provide the Opening(s) for the Electrical Connections

Electrical openings vary by unit size and arrangement and are field supplied.

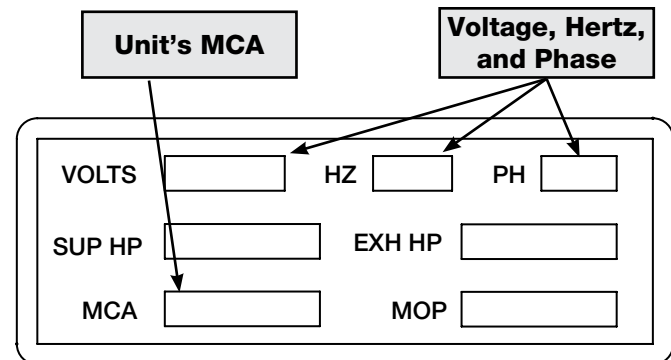

Electrical Nameplate

Step 3 Connect the Main Power

Connect the main power lines to the disconnect switch and main grounding lug(s). Torque field connections to 20 in-lbs. See the control center layout in the reference section for main disconnect and grounding lug(s) locations.

Installation - Direct Gas Piping

IMPORTANT!

All gas piping must be installed in accordance with the latest edition of the National Fuel Gas Code ANSI/ Z223.1 and any local codes that may apply. In Canada, the equipment shall be installed in accordance with the Installation Code for Gas Burning Appliances and Equipment (CGA B149) and Provincial Regulations for the class. Authorities having jurisdiction should be consulted before installations are made.

WARNING!

All components of this or any other gas fired heating unit must be leak tested prior to placing the unit into operation. A soap and water solution should be used to perform this test. NEVER test for gas leaks with an open flame.

WARNING!

If pressure testing in excess of 1/2 psig (3.5 kPa), the heater and manual shutoff valve must be disconnected from the supply gas line.

WARNING!

If pressure testing at or below 1/2 psig (3.5 kPa), the heater must be isolated from the supply gas line by closing its manual shutoff valve.

IMPORTANT!

All piping should be clean and free of any foreign matter. Foreign material entering the gas train can damage the valves, regulators and burner.

IMPORTANT!

Do NOT connect the unit to gas types other than what is specified and do NOT connect the unit to gas pressures that are outside of the pressure range shown on the label.

Step 1 Determine the Supply Gas Requirements

The unit's direct gas nameplate states the requirements for the gas being supplied to the unit. The direct gas nameplate is located on the outside of the unit on the control center side.

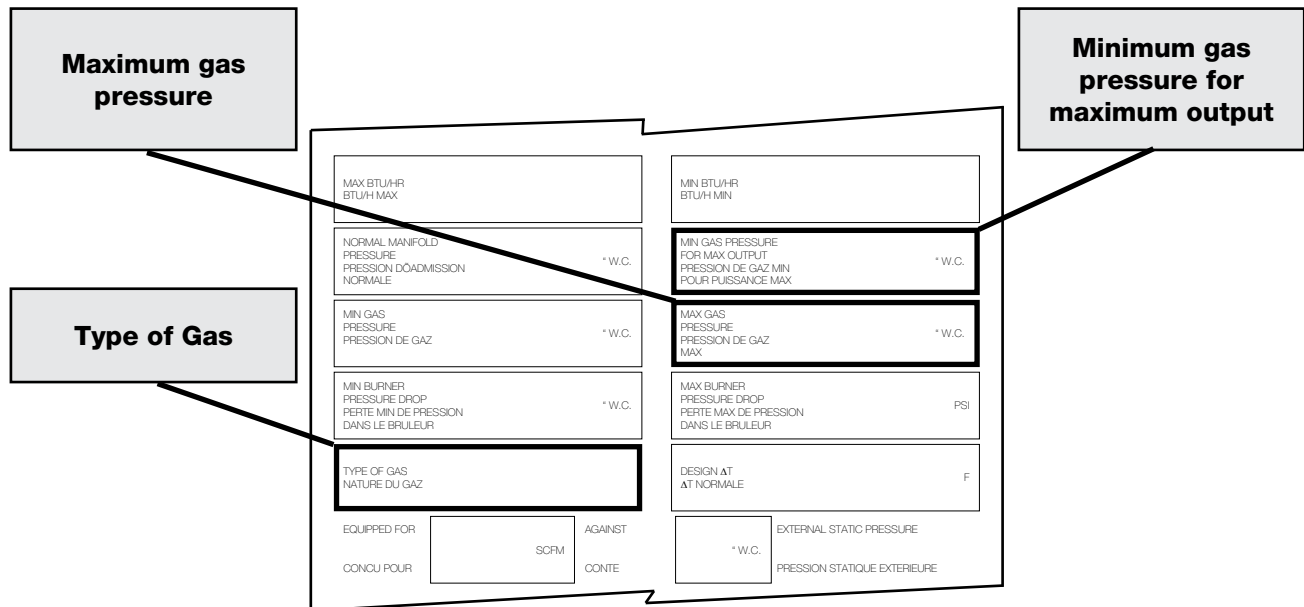

Direct Gas Nameplate

Installation - Direct Gas Piping

Step 2 Install Additional Regulator if Required

When the supply gas pressure exceeds the maximum gas pressure shown on the direct gas nameplate, an additional regulator (by others) is required to reduce the pressure. The regulator must have a listed leak limiting device or it must be vented to the outdoors.

NOTE!

The regulator located inside the unit is used to adjust the unit's maximum output temperature.

Step 3 Connect the Supply Gas Line

A manual shut off valve (gas cock), 1/8 in. (3.175 mm) plugged test port and 6 in. (152.4 mm) drip leg must be installed prior to the gas train. The valve and the test port must be accessible for the connection of a test gauge. Supply gas connections must be made by a qualified installer and are not furnished by Accurex.

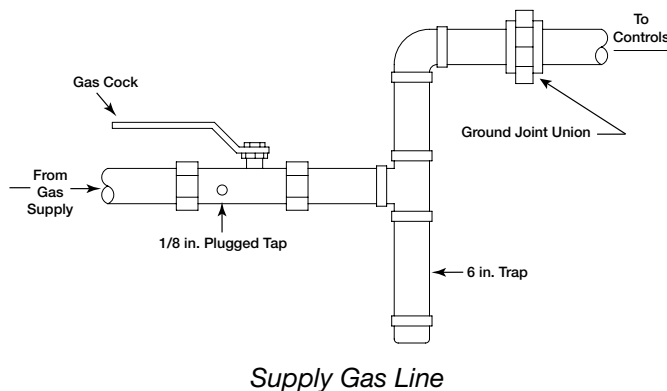

Step 4 Test the System for Leaks

Check both the supply lines and the factory piping for leaks. Apply a soap and water solution to all piping and watch for bubbling which indicates a leak.

WARNING!

NEVER test for a gas leak with an open flame.

WARNING!

The factory piping has been checked for leaks, but should be rechecked due to shipping and installation.

Start-Up - Blower

Pre-Start-Up Check

Rotate the fan wheel by hand and make sure no parts are rubbing. Check the V-belt drive for proper alignment and tension (a guide for proper belt tension and alignment is provided in the belt maintenance section). Check fasteners, set screws and locking collars on the fan, bearings, drive, motor base and accessories for tightness. Remove any shipping fasteners from the blower vibration isolators.

WARNING!

Disconnect and lock-out all power and gas before performing any maintenance or service to the unit. Failure to do so could result in serious injury or death and damage to equipment.

WARNING!

Check the housing, blower, weatherhood, and ductwork for foreign objects and debris before the blower is run.

SPECIAL EQUIPMENT REQUIRED

Below is a list of special tools that are required. A recommended model is shown, but equivalent products may be used.

Description	Manufacturer-Model	Phone	Website
Voltage Meter	Fluke-179	1-800-44-FLUKE	www.fluke.com
Amperage Meter	Fluke-179	1-800-44-FLUKE	www.fluke.com
Thermometer	Fluke-50	1-800-44-FLUKE	www.fluke.com
Micro Amp Meter	Fluke-16	1-800-44-FLUKE	www.fluke.com
U-Tube manometer	Dwyer-Slack Tube	1-219-897-8000	www.dwyer-inst.com
Tachometer	Monarch-Pocket Tach 100	1-800-999-3390	www.monarchinstruments.com

Step 1 Check the Voltage

Before starting the unit, compare the supplied voltage, hertz, and phase with the unit and motor's nameplate information. The nameplate is located on the outside of the unit on the control panel side.

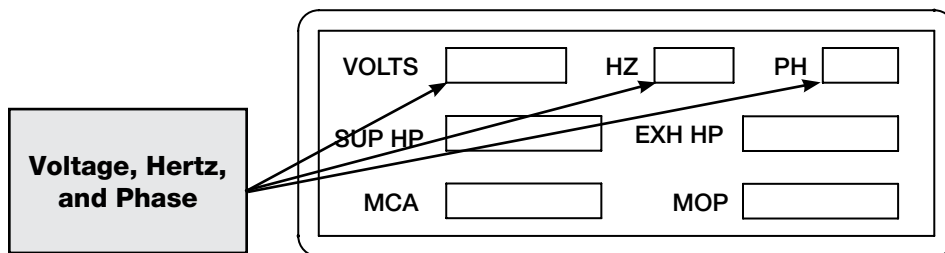

Electrical Nameplate

Step 2 Check the Blower Rotation

Open the blower access door and run the blower momentarily to determine the rotation. Arrows are placed on the blower scroll to indicate the proper direction.

NOTE!

To reverse the rotation on three phase units, disconnect and lock-out the power, then interchange any two power leads.

NOTE!

To reverse the rotation on single phase units, disconnect and lock-out the power, then rewire the motor per the manufacturer's instructions.

IMPORTANT!

If the blower is rotating in the wrong direction, the unit will move some air, but will not perform as designed. Be sure to perform a visual inspection to guarantee the correct blower rotation.

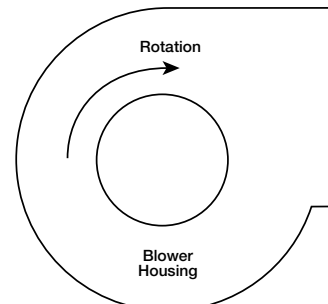

Blower Rotation

Start-Up - Blower

Step 3 Check for Vibration

Check for unusual noise, vibration or overheating of the bearings. Reference the troubleshooting section for corrective actions.

IMPORTANT!

Excessive vibration may be experienced during the initial start-up. Left unchecked, it can cause a multitude of problems including structural and/or component failure.

IMPORTANT!

Generally, fan vibration and noise is transmitted to other parts of the building by the ductwork. To minimize this undesirable effect, the use of heavy canvas duct connectors is recommended.

Step 4 Motor Check

Measure the motor's voltage, amps and RPM's and compare to the specifications on the motor's nameplate. Check the overload setting and make sure it matches the motor's amperage rating. If the motor's actual amps are greater than the nameplate amps, check and correct the supply voltage or air volume of the blower.

Step 5 Air Volume Measurement and Check

Measure the unit's air volume (CFM) and compare it with its rated air volume. If the air volume is off, adjust the fan's RPM's by changing/adjusting the drive.

NOTE!

The most accurate way to measure the air volume is by using a pitot traverse method downstream of the blower. Other methods can be used but should be proven and accurate.

IMPORTANT!

Changing the air volume can significantly increase the motor's amps. If the air volume is changed, the motor's amps must be checked to prevent overloading the motor.

NOTE!

To ensure accuracy, be sure the dampers are open when checking the air volume.

Step 6 Set-up Heating Inlet Air Sensor

The heating inlet air sensor will automatically turn the heat on if the outdoor air temperature is below the set point while the fan is operating.

- Typical setting: 55-65° F (12.8-18.3°C)

Start-Up - Direct Gas

IMPORTANT!

For proper unit function and safety, follow the start-up procedure in the exact order that it is presented.

IMPORTANT!

This start-up should begin after all of the installation procedures and the Blower start-up have been completed.

Step 1 Check the Supply Gas Pressure

Check the supply gas pressure and compare it with the unit's nameplate pressure requirements. Adjust the supply regulator as needed until the supply gas pressure is within the specified range. The nameplate is located on the outside of the unit on the control panel side.

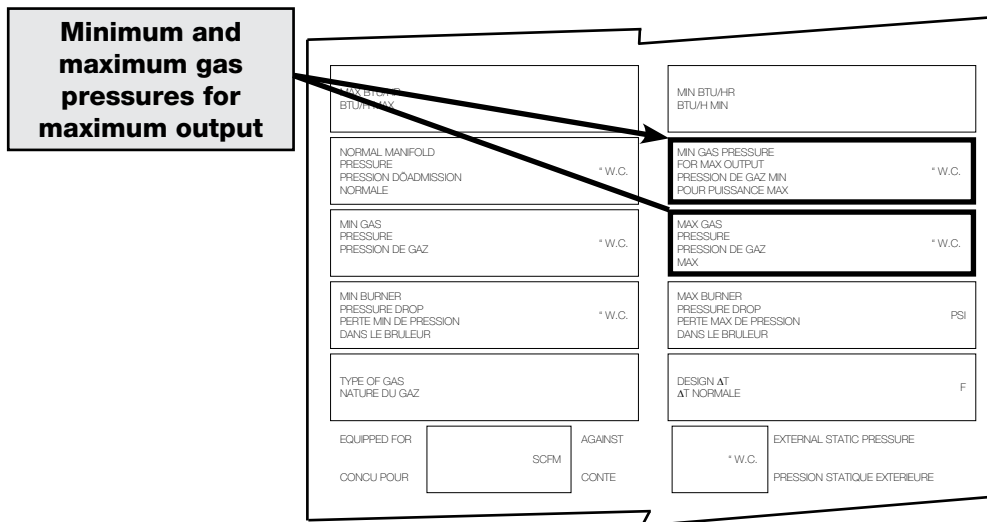

Direct Gas Nameplate

Start-Up - Direct Gas

IMPORTANT!

Proper air velocity over the burner is critical on direct fired gas units. If the air velocity is not within the unit specifications, the unit will not operate efficiently, may have sporadic shutdowns and may produce excessive carbon monoxide (CO) or other gases.

Step 2 Set the Burner Air Pressure Differential

With all filters, the blower access door in place, and the fan running and discharging 70° F (21.1°C) air, connect a U-Tube manometer (inside the unit control center) upstream and downstream of the burner baffle (see bottom of page). Measure the static pressure across the burner.

The proper static pressure should be between 0.625 and 0.675 inches wc (155.68 and 168.14 Pa) If needed, evenly adjust the baffles above and below the burner, keeping the burner centered in the opening until the required pressure is obtained. (Refer to drawing at right).

NOTE!

The pressure drop was set at the factory and may not need adjustment.

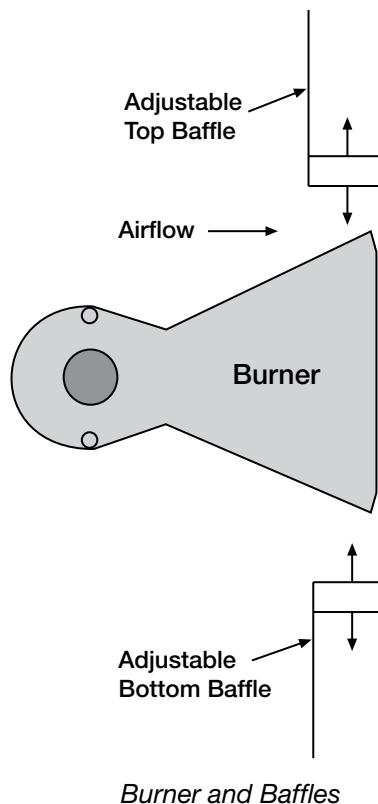

IMPORTANT!

This process may need to be repeated until the proper pressure is achieved. This adjustment will change the air quantity delivered by the unit and therefore the air quantity delivered should be rechecked. Refer to the blower start-up section.

NOTE!

To increase the static pressure decrease the opening. To decrease the static pressure increase the opening.

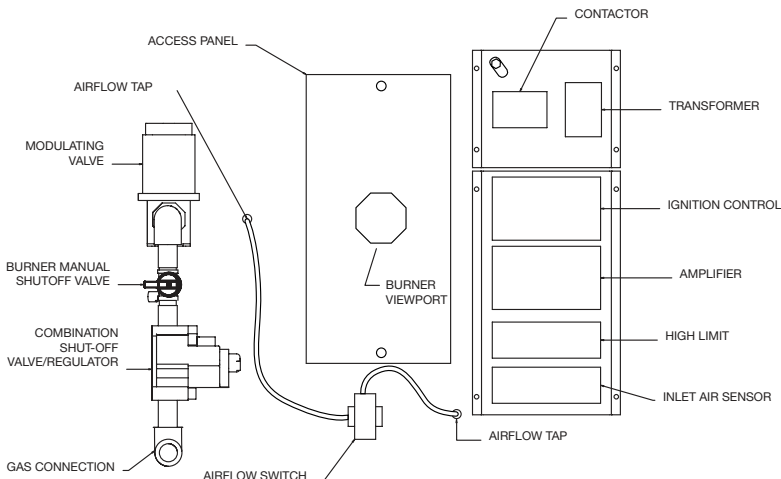

Unit Control Center

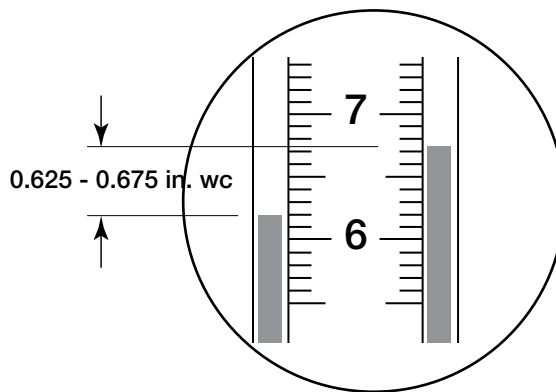

Start-Up - Direct Gas

Step 3 Set the Low Fire Time Delay

Set the low fire time delay to 75% of its maximum setting. See Maxitrol Series 14 picture below for the location of the time delay setting.

NOTE!

The low fire time delay must be set high enough to provide at least 15 seconds of low fire while the unit tries to light.

Step 4 Set the Maximum Firing Rate

Monitor the unit's actual temperature rise by placing a thermocouple in the unit's inlet and a second in the discharge, three duct diameters downstream of the burner.

Send the unit to maximum fire by disconnecting and isolating the wire connected to Terminal 4 on the Maxitrol amplifier shown.

While monitoring the units temperature rise, set the maximum firing rate by adjusting the regulator (shown below) until the designed temperature rise is achieved. After setting the maximum firing rate, reconnect the wire to the amplifier.

IMPORTANT!

Setting the maximum firing rate during mild weather conditions may cause the high limit to trip out during extreme conditions requiring manual resetting.

Low fire time delay setting (75% of maximum)

Remove the wire from terminal #4 to send the unit to maximum fire



Maxitrol Series 14

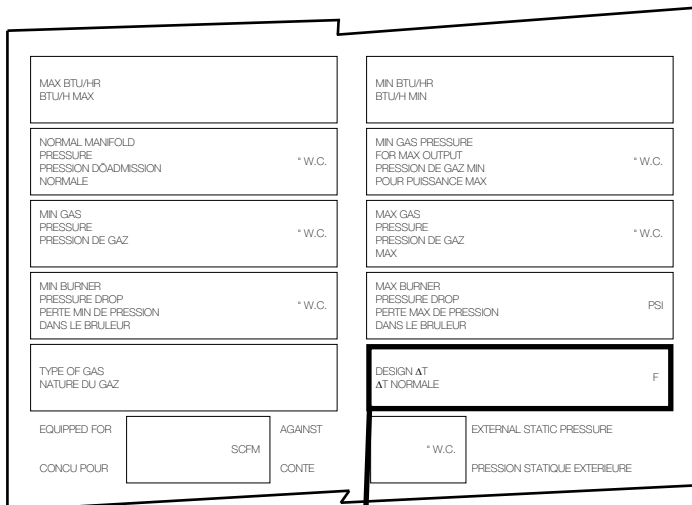

Direct Gas Nameplate

WARNING!

Do not set the burner maximum firing rate based on gas pressure. It should be set based on the unit's designed temperature rise shown on the direct gas label.

Maximum firing rate adjustment



Combination Valve

NOTE!

Clockwise rotation increases the temperature rise, counterclockwise rotation decreases the temperature rise.

NOTE!

The minimum setting for the maximum firing rate may be higher than required. This is acceptable, the burner will modulate as needed.

Start-Up - Direct Gas

Step 5 Set the Minimum Firing Rate

Disconnect and isolate one of the wires running to the modulating valve to send the unit to its minimum firing rate. Set the minimum firing rate by adjusting the needle valve shown in picture below.

After setting the minimum firing rate, reconnect the wire to the modulating valve.

IMPORTANT!

The proper minimum firing rate setting results in a small ribbon of continuous flame which covers the flame rod and runs across the entire burner.

IMPORTANT!

Do not allow the disconnected wire to come in contact with a potential ground, damage to the amplifier or transformer could result.

NOTE!

Counterclockwise rotation increases the minimum fire rate setting, clockwise rotation decreases the setting.

NOTE!

Adjusting the maximum and minimum fire may require the inlet air sensor to be initially set higher than desired in order to start the burner. Once high and low fire have been set, the inlet air sensor should be turned down to the desired temperature.

IMPORTANT!

The minimum firing rate setting is critical. If the settings is too high, the unit may not light, too low and the flame rod may not detect the flame.

Remove one wire to send the unit to the minimum firing rate.

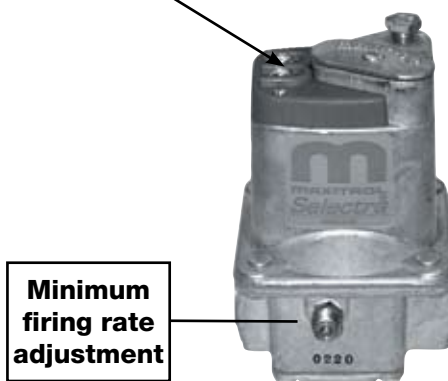

Modulating Valve

Set the discharge temperature (65°F (18.3°C) Typical)

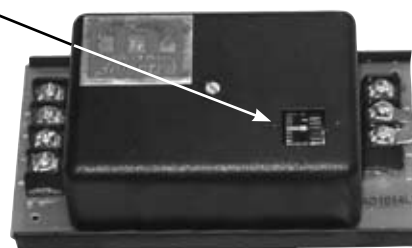

Maxitrol Series 14 Discharge Temperature Control

Step 6 Set the Unit's Discharge Temperature

Set the discharge temperature that will provide the desired space temperature.

IMPORTANT!

The Maxitrol Series 14 should be set to the desired discharge temperature. The temperature selector is built into the amplifier.

Step 7 Flame Signal Check

To measure the flame signal connect a micro amp meter to terminals (FC+) and (FC-) on the Fenwal flame safe guard. The flame signal should be above 1.0 micro amp and steady.

Check the flame signal with the burner at minimum fire, mid-fire and high-fire.

NOTE!

If the flame signal is not above 1.0 micro amp and steady, consult the troubleshooting section.

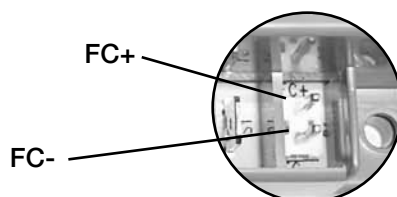

Flame Safe Guard

Troubleshooting

Blower Does Not Operate

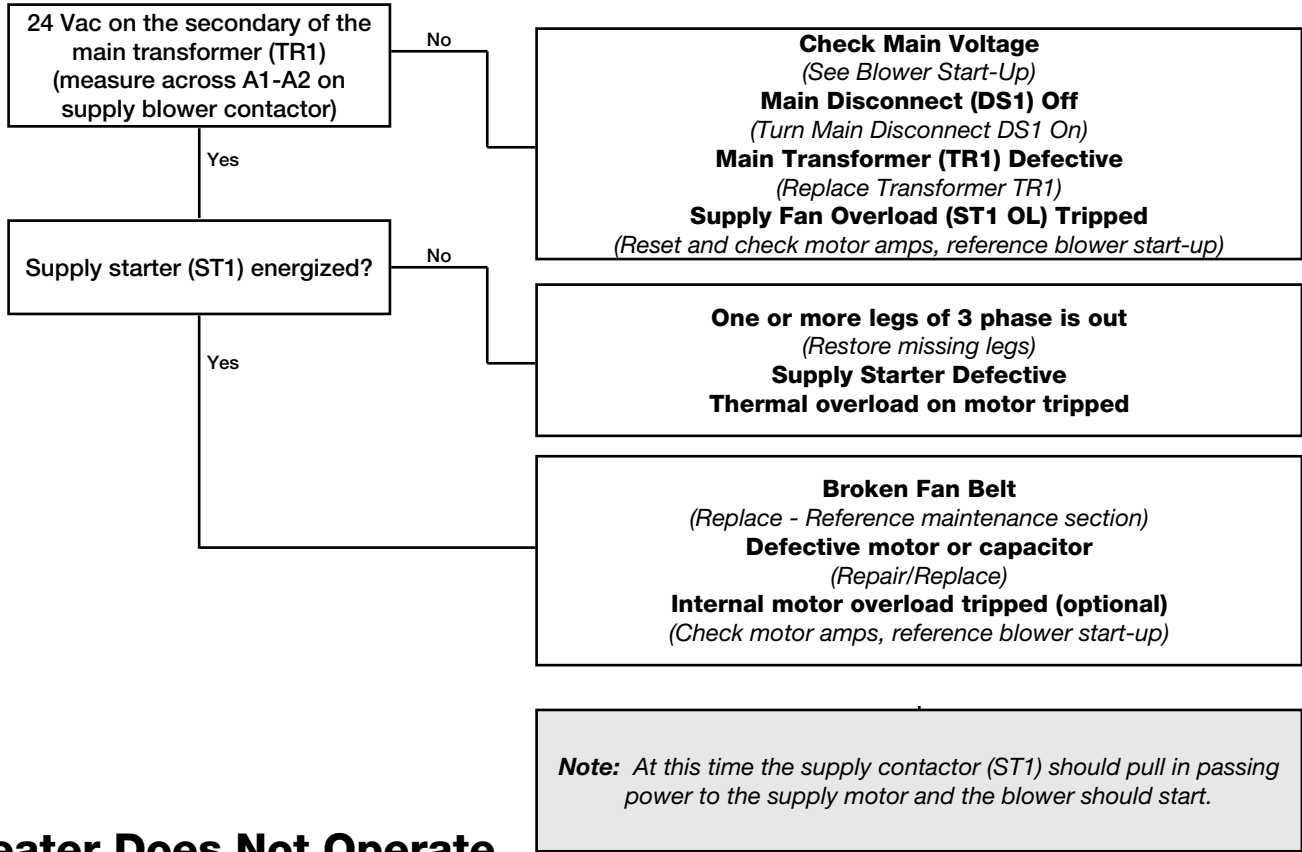

Heater Does Not Operate

Does not attempt to light (No visible spark)

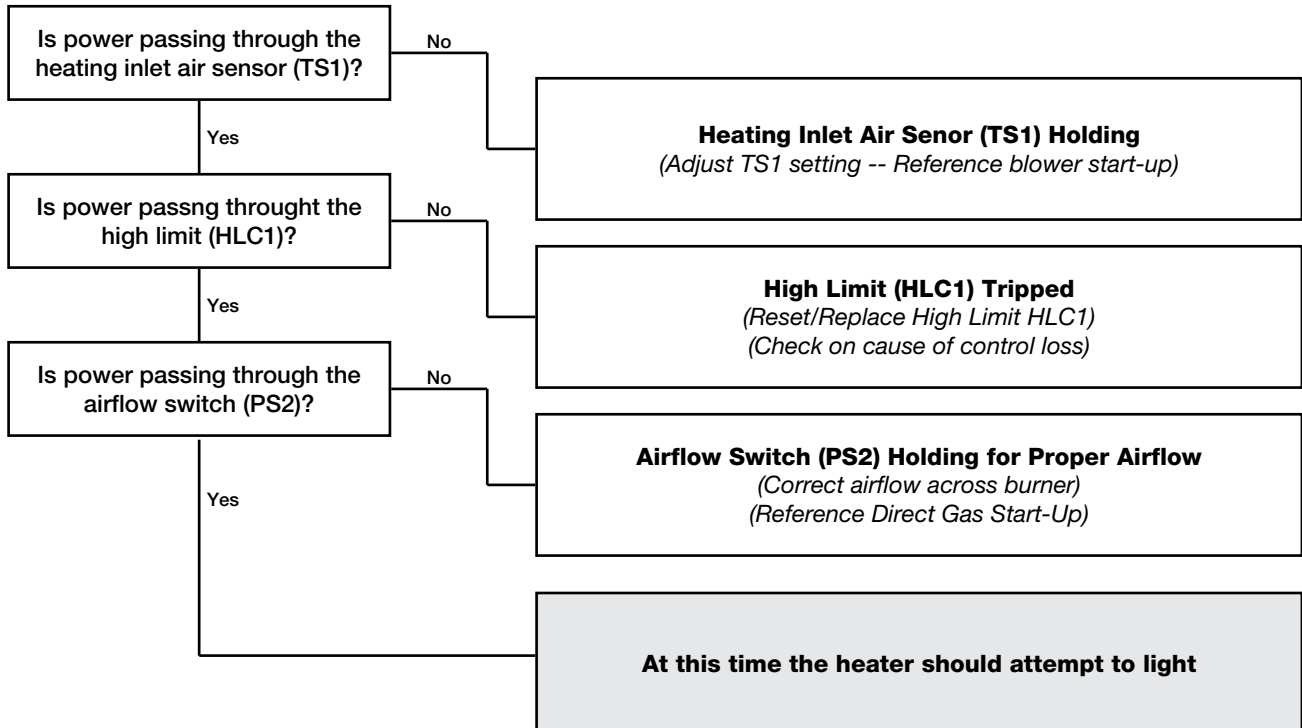

Troubleshooting

Heater Does Not Operate

Attempts to light but no flame (Visible spark)

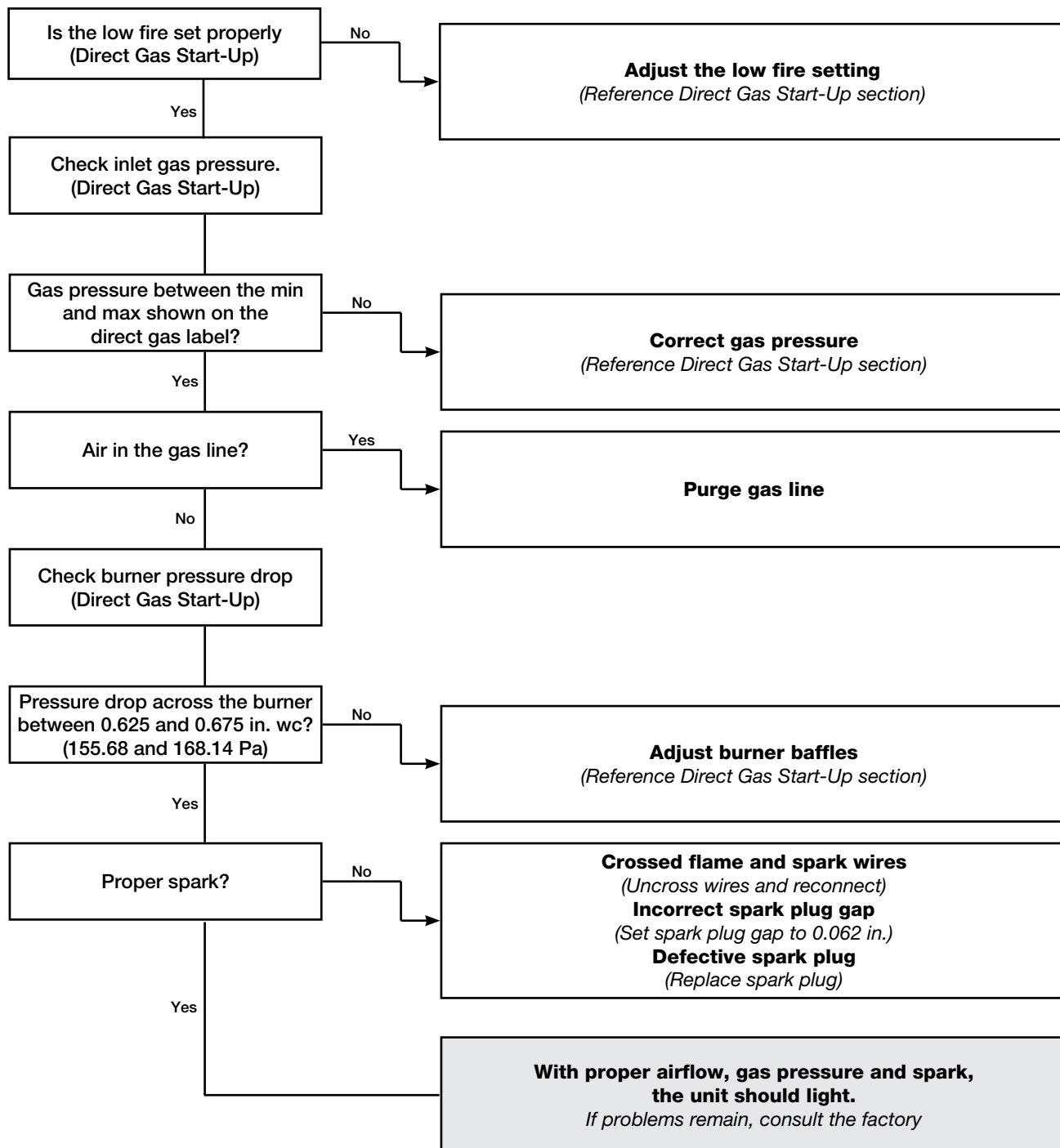

Troubleshooting

Excessive Noise or Vibration

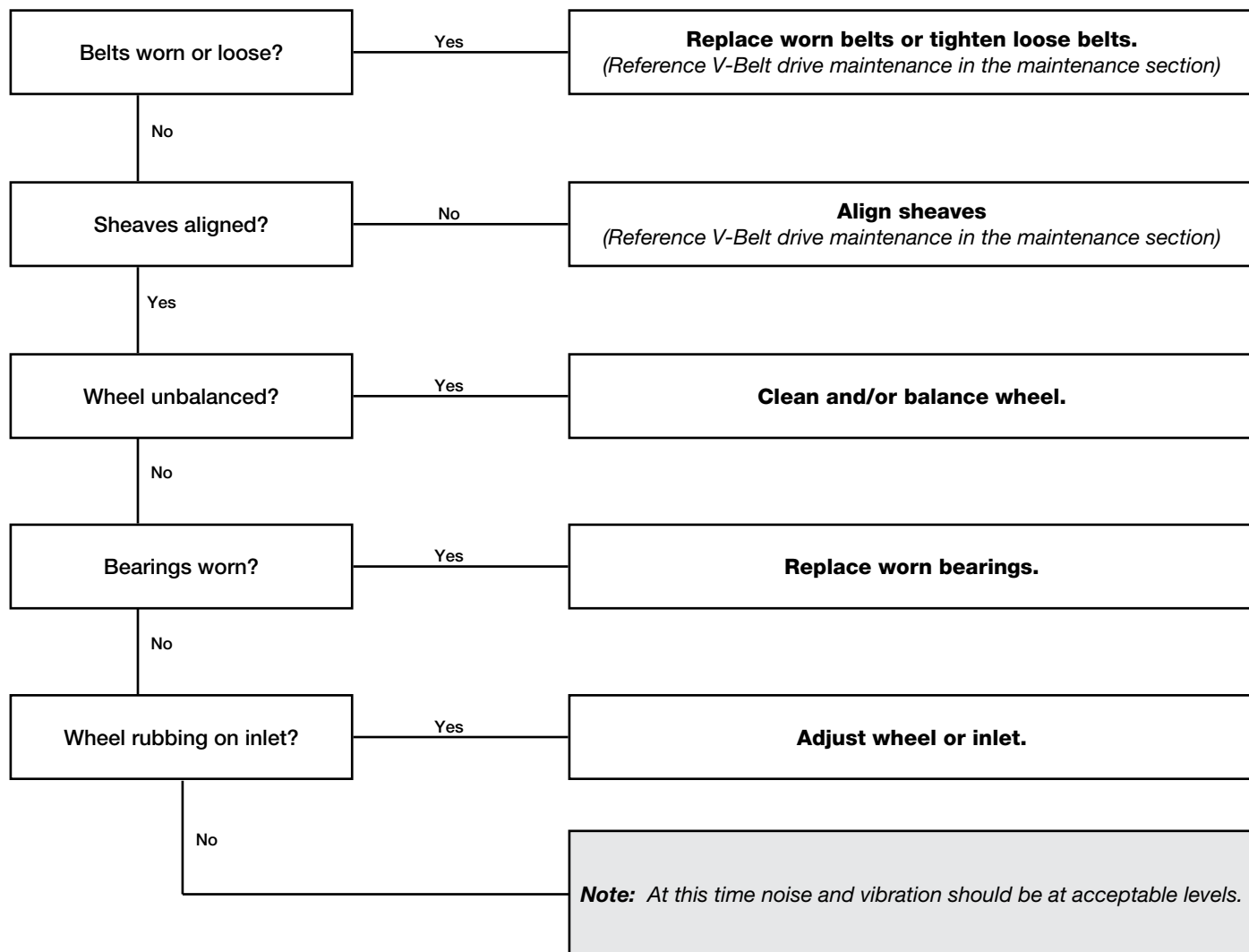

Maintenance - Routine

CAUTION!

Lock-out the gas and the electrical power to the unit before performing any maintenance or service operations to this unit.

V-Belt Drives

V-belt drives must be checked on a regular basis for wear, tension, alignment and dirt accumulation.

Check the tension by measuring the deflection in the belt as shown below.

Check the alignment by using a straight edge across both sheaves as shown below.

IMPORTANT!

Premature or frequent belt failures can be caused by improper belt tension, or misaligned sheaves.

Abnormally high belt tension or drive misalignment will cause excessive bearing loads and may result in failure of the fan and/or motor bearings.

Abnormally low belt tension will cause squealing on start-up, excessive belt flutter, slippage and overheated sheaves

IMPORTANT!

Do not pry belts on or off the sheave. Loosen belt tension until belts can be removed by simply lifting the belts off the sheaves.

IMPORTANT!

When replacing V-belts on multiple groove drives all belts should be changed to provide uniform drive loading.

IMPORTANT!

Do not install new belts on worn sheaves. If the sheaves have grooves worn in them, they must be replaced before new belts are installed.

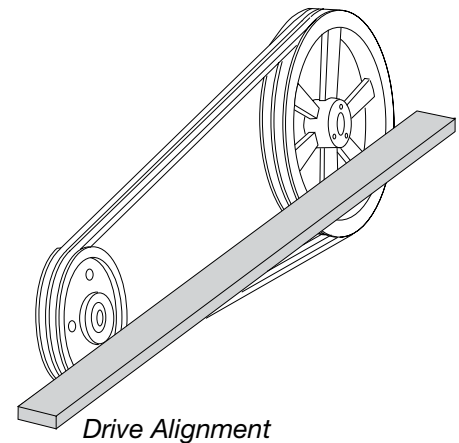
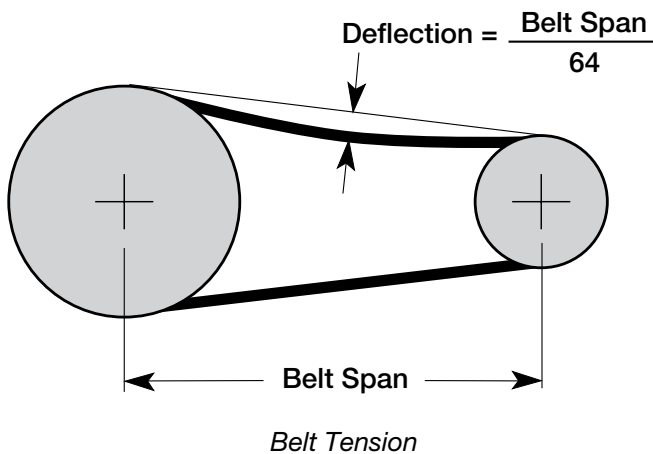

Motors

Motor maintenance is generally limited to cleaning and lubrication (where applicable).

Cleaning should be limited to exterior surfaces only. Removing dust and grease build-up on the motor assures proper motor cooling.

Motors supplied with grease fittings should be greased in accordance with the manufacturer's recommendations.

IMPORTANT!

Do not allow water or solvents to enter the motor or bearings. Motors and bearings should never be sprayed with steam, water or solvents.

IMPORTANT!

Greasing motors is only intended when fittings are provided. Many motors are permanently lubricated, requiring no additional lubrication.

Maintenance - Routine

Wheels

Wheels require little attention when moving clean air. Occasionally oil and dust may accumulate on the wheel causing imbalance. When this occurs the wheel and housing should be cleaned to assure proper operation.

Filters

Filter maintenance is generally limited to cleaning and replacement.

The aluminum mesh filters can be washed in warm soapy water.

An adhesive spray can be added to aluminum mesh filters to increase their efficiency.

IMPORTANT!

When reinstalling filters be sure to install them with the airflow in the correct direction. An airflow direction arrow is located on the side of the filters.

IMPORTANT!

Greasing motors is only intended when fittings are provided. Many motors are permanently lubricated, requiring no additional lubrication.

Maintenance - Fall

Start-Up

Repeat the Blower Start-Up procedure #4 and Direct Gas Start-Up procedure #1 and #2. This will ensure that the gas and air are set properly before the heating season begins, and should lead to trouble free operation all winter.

High Limit

The high limit switch may have tripped over the summer, it should be checked and reset if necessary.

Burner

Inspect the burner for accumulation of scales on both the upstream and downstream sides of the mixing plates. Any scaling or foreign material should be removed with a wire brush.

Visually check that all holes in the mixing plates are clear. If any burner ports are plugged (even partially), clear them with a piece of wire or another appropriate tool.

Replace or tighten any loose or missing fasteners on the mixing plates. Always use zinc plated or stainless steel fasteners.

Inspect and clean the flame and spark rod. Occasional replacement of the flame rod and spark rod may be necessary to ensure optimum unit performance.

WARNING!

Do not enlarge burner ports when clearing a blockage, performance could be affected.

NOTE!

Flame rods can last many years, but because of thermal expansion of the porcelain, flame rods can fail over time.

Maintenance Log

Unit Model Number _____ (e.g. XDGK-109-H15)
 Unit Serial Number _____ (e.g. 04C99999 or 10111000)
 Start-up date _____ (MM/DD/YYYY)
 Start-up Personnel Name _____
 Start-up Company _____
 Phone Number _____

Pre Start-Up Checklist - check boxes as items are completed

- Check tightness of all factory wiring connections
- Hand-rotate blower to verify free rotation
- Verify supply voltage to the main disconnect
- Verify the supply gas pressure

Start-Up Blower Checklist - refer to IOM for further detail

- Check line voltage L1-L2 _____ L2-L3 _____ L1-L3 _____
- Check blower rotation
- Check for vibration
- Supply fan RPM _____ RPM
- Motor nameplate amps _____ Amps
- Actual motor amps _____ Amps
- Actual CFM delivered _____ CFM

Component

- Heating inlet air sensor _____ Actual Setting (Typical Setting 55-65° F (12.8-18.3°C))

Start-Up Direct Gas - refer to IOM for further detail

- Check supply gas pressure _____ Maximum _____ Minimum _____ Actual
- Set burner pressure differential _____ Actual Setting (Typical 0.65 in. wc.)
- Set the maximum firing rate _____ temp rise
- Set the minimum firing rate _____ check
- Set the unit's operating temperature _____ degrees F

Maintenance Log

Date	Time	Notes



Reference

Typical Gas Train Layout less than 400 MBH

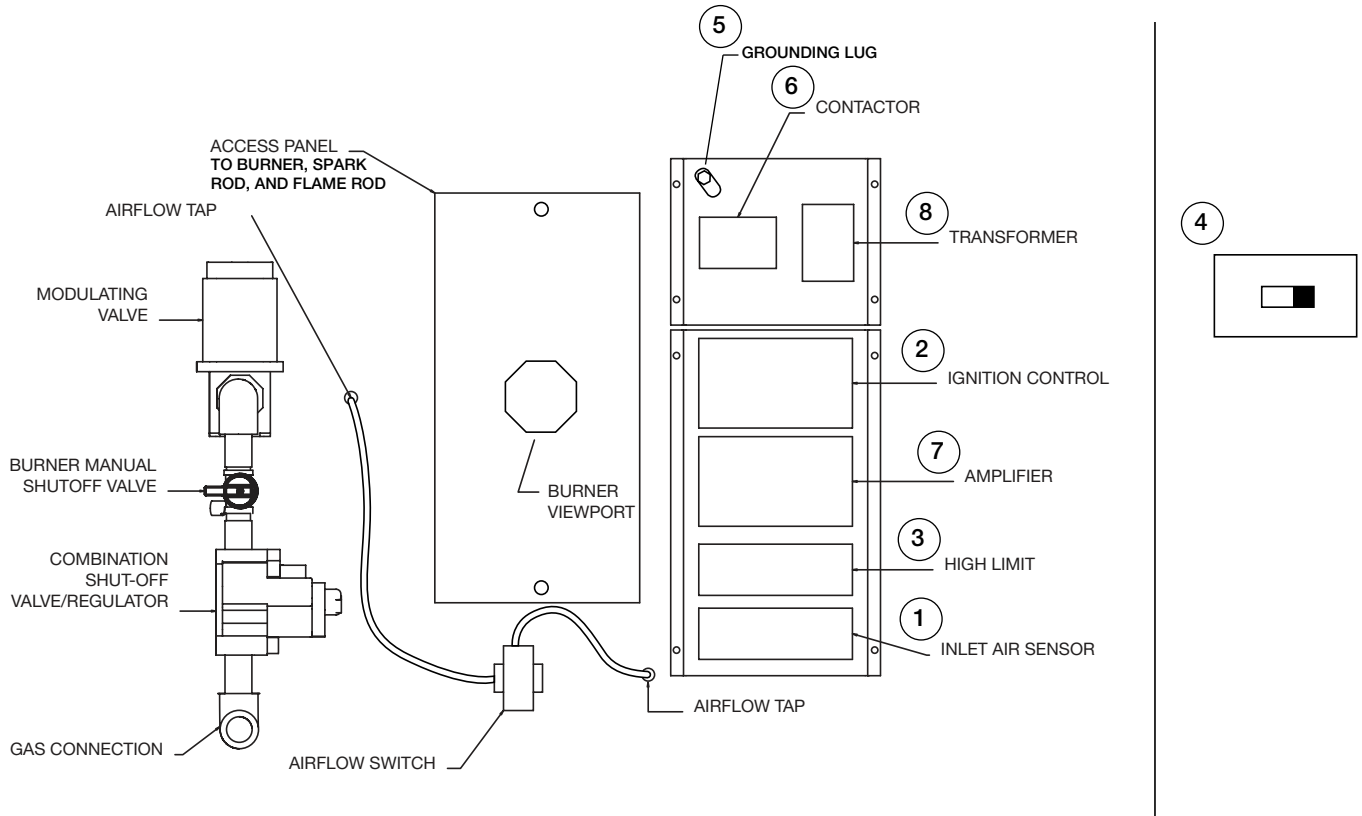

NOTE!

This is a typical gas train. The gas train in your unit may be different.

1. Heating Inlet Air Sensor - Ductstat that automatically energizes burner when inlet air temperature falls below set point.
2. Ignition Control - Monitors flame, shuts down unit when unsafe conditions are detected.
3. High Limit - Prevents unit from discharging air above a set point.
4. Main Disconnect - On/Off switch, provides single point power connection to unit.
5. Grounding Lugs - Completes electrical circuit
6. Motor Starter - 24 Volt magnetic contacts for starting motor, 3 phase motors have electronic overload.
7. Amplifier - Controls modulating valve, assures the desired temperature is delivered.
8. Control Transformer - Provides 24 volts for controls.

WARRANTY

Accurex warrants this equipment to be free from defects in material and workmanship for a period of one year from the date of purchase. Any units or parts which prove to be defective during the warranty period will be replaced at our option when returned to our factory, transportation prepaid. Motors are warranted by the motor manufacturer for a period of one year. Should motors furnished by Accurex prove defective during this period, they should be returned to the nearest authorized motor service station. Accurex will not be responsible for any removal or installation costs.

As a result of our commitment to continuous improvement, Accurex reserves the right to change specifications without notice.



P.O. Box 410 Schofield, WI 54476
Phone: 888.333.1400 Fax: 715.241.6191
www.accurex-systems.com

*IOM XDGK Rev. 1 June 2007
Copyright © 2007 Accurex*