

## Reference Guide for the DDC Controller

Please read and save these instructions. Read carefully before attempting to operate or maintain the product described. Protect yourself and others by observing all safety practices. Failure to comply with instructions could result in personal injury and/or property damage! Retain instructions for future reference.

**TAP v1.04**

**Version Date: June 13, 2011**

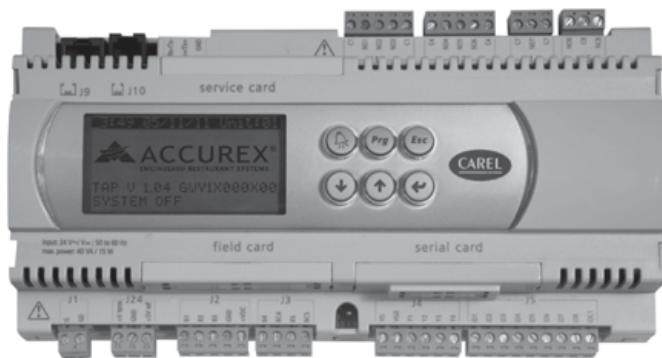

### Introduction

#### Program Features

The DDC controller offers improved control through easy monitoring and adjustment of unit parameters by way of a lighted graphical display and a push-button keypad. The controller also has the ability to communicate with a BMS (Building Management System) through protocols such as LonWorks®, BACnet® MSTP, BACnet® IP or Modbus. See Points List on page 26 for a complete list of BMS points.

#### Pre-Programmed Operating Sequences

The controller has been pre-programmed to offer multiple control sequences to provide tempered air. Factory default settings allow for easy setup and commissioning. The sequence parameters are fully adjustable. The controller is ready from the factory with pre-set operating sequences:

- **Outdoor Air Temperature Reset**

The default operating sequence is supply air temperature control based on outdoor air temperature. The controller will monitor the outdoor air temperature and adjust the supply air temperature to provide comfortable conditions. This sequence provides simple and reliable control, reacting to changing outdoor air conditions. For more information, see the Sequence of Operation section of this manual.

- **Room Temperature Reset**

If an optional room temperature sensor is installed, the controller will automatically change its operating sequence. Similar to the default sequence, the controller will adjust the supply air temperature to satisfy the room temperature set point. For more information, see the Sequence of Operation section of this manual.

An optional room dehumidistat can also be used for room humidity control for both operating sequences.

#### BMS Communication

With the addition of an optional BMS Communication card, the user can remotely adjust set points, view unit status points and alarms. The DDC controller is capable of communicating over several protocols:

- BACnet® MSTP
- BACnet® IP/Ethernet
- LonWorks®
- Modbus

#### Internal Time Clock

The controller has an internal programmable time clock, allowing the user to add up to seven different occupancy schedules. The user may also add Holidays for additional energy savings.

#### Alarm Management

The DDC controller will monitor the unit conditions for alarm conditions. Upon detecting an alarm, the controller will record the alarm description, time, date, available temperatures, and unit status for user review. A digital output is reserved for remote alarm indication. Alarms are also communicated via BMS (if equipped).









#### Occupancy Modes

The DDC controller offers three modes of determining occupancy: a dry contact, the internal time clock or the BMS. If in the Unoccupied mode the unit will either be shut down, or will cycle on to maintain an adjustable unoccupied room temperature set point.

#### Remote Display Panel (Optional)

A touchpad display panel allows for remote monitoring and adjustment of parameters, allowing ease of control access without going outdoors.

## Table of Contents

Sequence of Operation . . . . .	2
General Operation . . . . .	2
Set Point Control . . . . .	3
Heating . . . . .	3
Cooling . . . . .	3
Dehumidification . . . . .	3
Reheat . . . . .	3
Alarms . . . . .	4
Energy Recovery Wheel Sequences . . . . .	6
Controller Overview . . . . .	5
Display Use . . . . .	6
Example of Parameter Adjustment . . . . .	6
Example of Alarms . . . . .	7
Main Menu Overview . . . . .	8-9
Menu Overview . . . . .	10-11
Menus	
A.  On/Off Unit . . . . .	12
B.  Setpoint . . . . .	12-13
C.  Clock/Scheduler . . . . .	15
D.  Input/Output . . . . .	15
E.  Data Logger . . . . .	15
F.  Board Switch . . . . .	16
G.  Service	
a. Information . . . . .	16
b. Overrides . . . . .	16-18
c. BMS Config . . . . .	18-20
d. Service Settings . . . . .	20
a. Working hour set. . . . .	20
b. Probe adjustment . . . . .	20
c. Password/Defaults . . . . .	20
H.  Manufacturer	
a. Configuration . . . . .	21
b. I/O Configuration . . . . .	21
c. Factory Settings . . . . .	21-25
d. Initialization . . . . .	25
Points List . . . . .	26
Auxiliary I/O (pCOe) . . . . .	27
Setup . . . . .	27
Troubleshooting . . . . .	28
NTC Temperature Sensor Chart . . . . .	28
BACnet MSTP Quick Start . . . . .	29
BACnet IP/Eth Quick Start . . . . .	30
Maintenance Log . . . . .	31
Warranty . . . . .	Backcover

## Sequence of Operation

The DDC controller can be configured for air handler, energy recovery and make-up air applications. Each application utilizes similar technologies for heating and cooling: chilled water, hot water, indirect gas, electric heat, packaged DX cooling, and packaged DX cooling with digital scrolls. All set points, lockouts and delays are user adjustable.

### General Operation

**UNIT START COMMAND:** The DDC controller requires a digital input to enable operation. The unit can then be commanded on or off by this digital input, the BMS or internal time clock.

- Initial delay
- Factory mounted and wired dampers are powered, *if equipped*. (Outdoor air, exhaust air, and recirculation air dampers).
- Exhaust fan starts after a 10 second delay, *if equipped*.
- Supply fan starts 5 seconds after the exhaust fan.
- Heating, cooling and wheel operation (page 3).

### UNIT STOP COMMAND (OR DE-ENERGIZED):

- Supply fan, exhaust fan, tempering, and wheel are de-energized.
- Outdoor air and Exhaust air damper dampers are closed after a 10 second delay.

**OCCUPIED/UNOCCUPIED MODES:** The DDC controller offers three modes of determining occupancy: a dry contact, the internal time clock or the BMS. When in the unoccupied mode, the unit will either be shut down, or will cycle on to maintain the unoccupied room temperature set point.

- **Occupied Mode:**
  - Exhaust fan on, *if equipped*.
  - Supply fan on.
  - Heating (refer to Heating section).
  - Cooling (refer to Cooling section).
  - Wheel control (page 4), *if equipped*.
- **Unoccupied Mode (Unit Off):** Default setting when there is no recirculation damper or room temperature sensor.
- **Unoccupied Mode (Cycle on Room):** Optional unoccupied mode when there is a recirculation damper and a room temperature sensor wired to unit.
  - Exhaust fan off, *if equipped*.
  - Supply fan off.
  - Recirculation air damper open.
  - OA damper closed.
  - Unoccupied heating is enabled when the room temperature is less than the unoccupied heating set point minus differential (65°F±5°F). The supply air temperature set point will be set to the supply maximum reset limit (90°F). The unit cycles off when the room temperature reaches the unoccupied heating set point plus differential.



## Sequence of Operation

- Unoccupied cooling is enabled when the room temperature is greater than the unoccupied cooling set point plus differential ( $85^{\circ}\text{F}\pm 5^{\circ}\text{F}$ ). The supply air temperature set point will be set to the supply minimum reset limit ( $55^{\circ}\text{F}$ ). The unit cycles off when the room temperature reaches the unoccupied cooling set point minus differential.

---

### Set Point Control

Supply air temperature set point can either be reset by outside air temperature, or room temperature. If equipped with BMS communications, the user can also directly set the supply temperature set point, or room temperature set point (if equipped with a room temp sensor).

- **Outdoor Air Temperature Reset Function:** Without a room temperature sensor, the controller will default to supply temperature reset based on outdoor air temperature. The controller will monitor the OA temperature and reset the supply temperature set point based upon the outdoor air reset function.
- **Room Temperature Reset (optional):** With a room temperature sensor, the controller will adjust the supply air temperature set point up/down accordingly to satisfy the desired room temperature. Cooling and heating are determined by a difference in temperature of the room temperature sensor compared to the desired room temperature set point.

---

### Heating

The heating is controlled to maintain the supply temperature set point. The heating will be locked out when the outside air temperature is above the heating lockout ( $70^{\circ}\text{F}$ ).

- **Indirect Gas Furnace:** DDC controller will modulate the indirect gas furnace to maintain the supply temperature set point.
- **Hot Water Coil:** DDC controller will modulate a hot water valve (provided by others) to maintain the supply temperature set point. **Coil Freeze protection must be provided by others in the field!**
- **Electric Heater:** DDC controller will modulate an electric heater to maintain the supply temperature set point.
- **Heat Pump:** DDC controller will stage compressor(s) to maintain the supply air set point. This signal will come wired to the factory provided heat pump module. **All external water valves and valve controls are provided, wired and mounted by others in the field, including freeze protection.**

### Cooling

The cooling is controlled to maintain the supply temperature set point. The mechanical cooling will be locked out when the outside air temperature is below the cooling lockout ( $55^{\circ}\text{F}$ ).

- **Chilled Water:** DDC controller will modulate a chilled water valve (provided by others) to maintain supply air set point. **Coil Freeze protection must be provided by others in the field!**
- **Packaged DX Cooling (Standard Scroll):** DDC controller will control stages of cooling to maintain the supply air set point.
- **Packaged DX Cooling (Digital Scroll):** DDC controller will modulate the digital scroll to maintain the supply air temperature set point.
- **Heat Pump:** DDC controller will power the reversing valve within the heat pump module to direct the refrigerant flow for airside cooling. The cooling is controlled to maintain the supply temperature set point. **All external water valves and valve controls are provided, wired and mounted by others in the field, including freeze protection.**

---

### Dehumidification

The cooling is controlled to maintain the cold coil set point. The Dehumidification sequence will be locked out when the OA is less than the dehumidification lockout ( $10^{\circ}\text{F}$ ) above the cold coil set point.

- **Optional Room Dehumidistat:** The room dehumidistat is a field mounted sensor that monitors the relative humidity (RH) of the room. If the RH exceeds set point, the dehumidistat will decrease the cold coil set point to the dehumidify set point ( $50^{\circ}\text{F}$ ) to further dry the supply air. Once the room dehumidistat is satisfied, the DDC controller will resume normal operation.

---

### Reheat

While the unit is in dehumidification mode, the supply air can be reheated via Primary Heating Source, On/Off Hot Gas Reheat or Modulating Hot Gas Reheat.

- **Primary Heating Source:** The main heating source is enabled to reheat the air to meet the supply temperature set point. (Except heat pump).
- **Modulating Hot Gas Reheat (bypass damper):** The DDC controller will open the On/Off hot gas reheat valve, and modulate the Hot Gas Reheat bypass damper to maintain the supply temperature set point.
- **Modulating Hot Gas Reheat (valve):** The DDC controller will modulate the hot gas reheat valve to maintain the supply temperature set point.
- **On/Off Hot Gas Reheat:** The DDC controller will open the On/Off hot gas reheat valve to maintain the supply temperature set point.



### Alarms

The DDC controller includes a digital output for remote indication of an alarm condition. Possible alarms include:

- **Dirty Filter Alarm:** If the outside air or return air filter differential pressure rises above the differential pressure switch set point, the DDC controller will activate an alarm.
- **Supply and Exhaust Air Proving Alarm:** DDC controller monitors proving switch on each blower and displays an alarm in case of blower failure.
- **Temperature Sensor Alarm:** DDC controller will send an alarm in the case of a failed air temperature sensor.
- **Supply Air Low Limit:** If the supply air temperature drops below the supply air low limit (35°F), the DDC controller will de-energize the unit and activate the alarm output after a preset time delay (300s).
- **Other Alarms:** Wheel Rotation, High Wheel Pressure, High/Low Refrigerant Pressure.

---

### Energy Recovery Wheel Sequences

**Economizer (optional):** If the unit is equipped with an energy recovery wheel, the economizer will modulate/stop the energy wheel to achieve free cooling. The economizer will be locked out when:

- The outside air is less than the economizer lockout (40°F).
  - The unit is operating in dehumidification mode.
  - The unit is operating in heating mode.
- **Stop Wheel:** When economizer mode is enabled and there is a signal for cooling, the wheel will stop rotating to allow free cooling.
  - **Modulate Wheel:** When economizer mode is enabled and there is a signal for cooling, the wheel VFD modulates wheel speed to maintain the supply temperature set point.

**Frost Control (optional):** The DDC controller will activate the frost control method when the outdoor air temperature is less than the defrost set point (5°F) and the wheel pressure switch is closed, due to a high wheel pressure drop.

- **Electric Preheater:** When frosting is occurring, the preheater is energized to defrost the wheel. Once the pressure drop decreases below the pressure switch set point, the preheater is de-energized.
- **Modulate Wheel:** When frosting is occurring, the VFD slows the wheel to allow defrosting to occur. Once the pressure drop decreases below the pressure switch set point, the wheel returns to full speed.

### Energy Recovery Wheel Sequences, continued

- **Timed Exhaust:** When frosting is occurring, the supply fan is cycled off along with the tempering for 5 minutes. The exhaust fan will continue to run, allowing the warm exhaust air to defrost the wheel. After the 5 minute cycle, the supply fan and tempering are re-energized to continue normal operation. The unit will continue normal operation for 30 minutes before allowing another defrost cycle to occur.



# Controller Overview

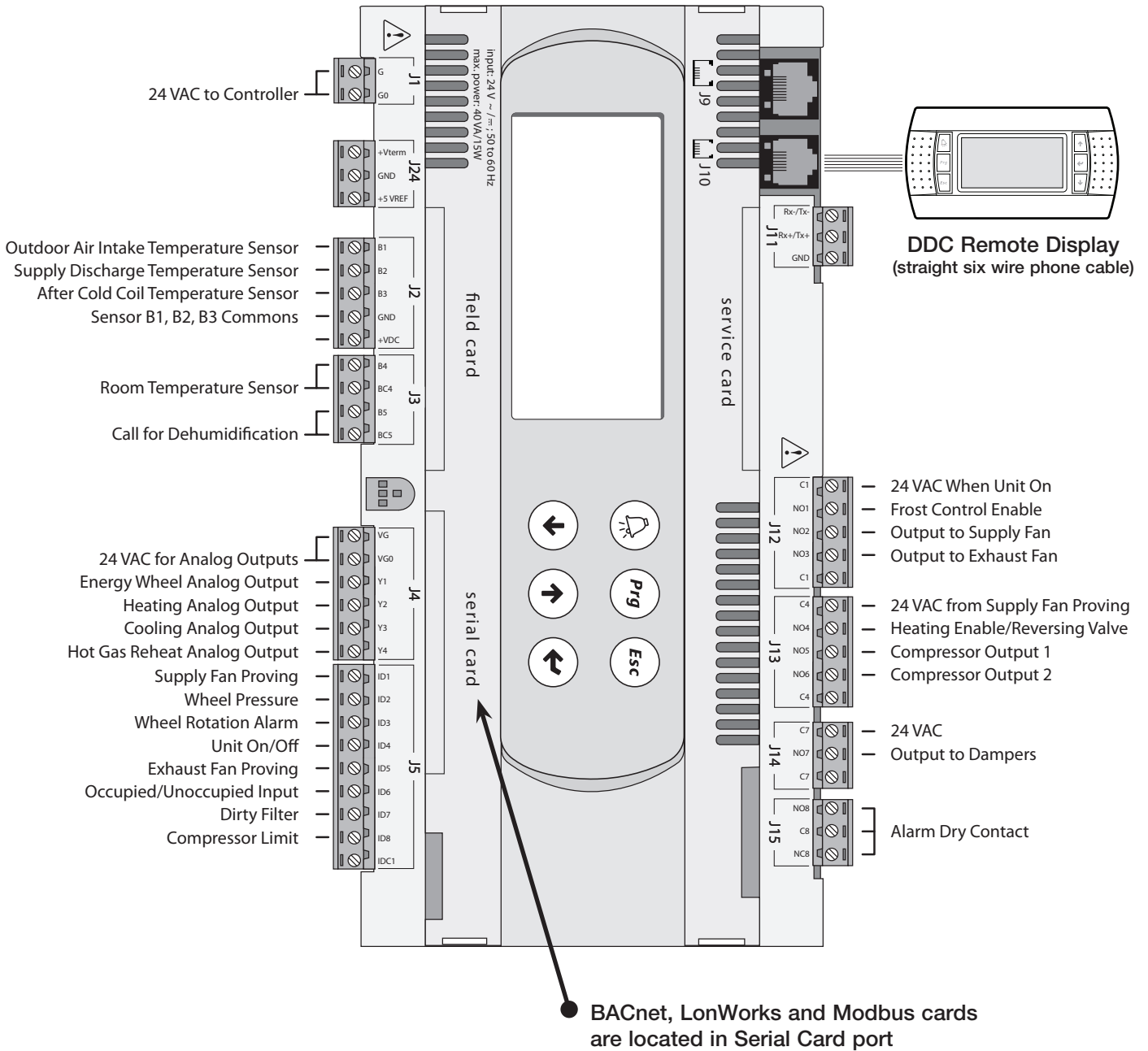

## Display Use

The DDC controller is located in the unit control panel. The face of the controller has six keys, allowing the user to view unit conditions and alter parameters. The DDC controller is pre-programmed with easy to use menus.

To change the display contrast, hold the Enter and Escape button while pressing the up and down arrows.

A remote mounted display is also available, which connects via the **J10** port. A six wire patch cable is needed.

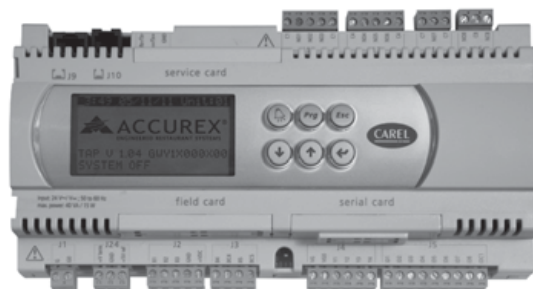

### Keypad Description

	Alarm	Button will blink red, indicating an alarm condition. Press to review current alarms. To review previous alarms, access the DATA LOGGER through the main menu.
	Down Arrow	The arrow keys allow the user to scroll through different screens and adjust parameters.
	Up Arrow	
	Enter	A. In screens with adjustable parameters, pressing the Enter key moves the cursor from the upper left corner of the screen to the parameter. The arrow keys can then be used to adjust the parameter. B. To move to the next parameter on the same screen, press the Enter button. C. To save the change, press the Enter button until the cursor moves back to the upper left corner of the screen.
	Escape	Allows the user to exit the current menu, jumping to the Main Menu.
	Program	Pressing the Prg (Program) button allows the user to enter the Main Program Menu. Refer to pages 8 and 9 for Main Program Menu description.

### Example of Parameter Adjustment

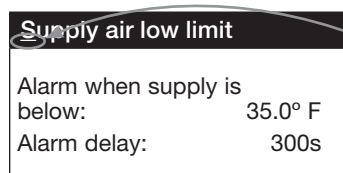

The cursor always begins in the upper left corner of the display and will be blinking. Press the key to move the cursor down for parameter adjustment.

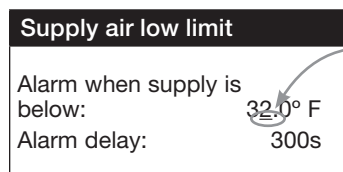

Once the cursor has reached the desired parameter, press the keys to adjust the value.

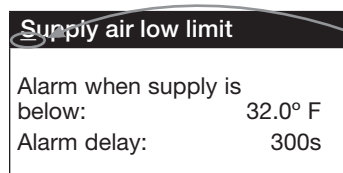

When satisfied with the adjustment, press the key to save the parameter. When finished, make certain the cursor is in the upper left corner. If the cursor is not in the upper left corner, the changes will not be saved. The cursor must be in the upper left corner to enable screen advancement.







## Examples of Alarms

If an alarm occurs, the  button will glow red on the controller and the remote display (if installed).

### Alarms

Press DOWN to review current alarm(s).  
Press ESC to exit.  
Press ALARM to reset.

To view alarm, press the  button once. This will display the most recent alarm. Press the  button again to reset the alarm. If the alarm cannot be cleared, the cause of the alarm has not been fixed. Press the   buttons to view any additional occurring alarms.

Outside Air Temperature  
Sensor B01 Failure

This is an example of an outdoor air sensor failure.

### Alarms

No active alarm



Press ENTER  
to DATA LOGGER

This screen appears if there are no active alarms.

To view all saved alarms, press the  button to enter the DATA LOGGER. For more information, see the Data Logger menu.

## Examples of Alarms

<b>Outdoor Air Temperature Sensor Failure</b>	Failure of outside air temperature sensor.	Alarm only
<b>Supply Air Temperature Sensor Failure</b>	Failure of supply air temperature sensor.	Alarm & Shutdown
<b>Cold Coil Temperature Sensor Failure</b>	Failure of after cooling coil air temperature sensor.	Alarm only
<b>Room Temperature Sensor Failure</b>	Failure of room temperature sensor. (If UnOccupied - Cycle On Room is enabled)	Alarm only
<b>System has exceeded the set number of run hours</b>	The unit has been operating for a period longer than the maintenance set point.	Alarm only
<b>Supply airflow</b>	Indicates a loss of airflow in the supply fan.	Alarm & Shutdown
<b>Wheel Pressure - Dirty Wheel/High CFM</b>	Indicates a buildup of pressure across the energy wheel.	Alarm only
<b>Energy recovery wheel rotation. Check wheel.</b>	Indicates a wheel rotation failure.	Alarm only
<b>Exhaust Airflow</b>	Indicates a loss of airflow in the exhaust fan.	Alarm & Shutdown
<b>Filter Alarm</b>	Indicates a buildup of pressure across the filters.	Alarm only
<b>A compressor limit switch has tripped</b>	Indicates a high or low refrigerant pressure switch has tripped.	Alarm only
<b>Supply temperature low limit alarm</b>	Indicates a supply air temperature lower than the supply low limit set point.	Alarm & Shutdown
<b>pCO<sub>e</sub> Offline</b>	Indicates communication with pCO <sub>e</sub> auxiliary I/O has failed.	Alarm only
<b>pCO<sub>e</sub> - Analog input probe on channel # disconnected or broken</b>	Indicates an analog probe failure on the pCO <sub>e</sub> . Check integrity of auxiliary I/O analog probes.	Alarm only

## Main Menu Overview

The DDC controller will revert to a default main menu loop. This loop includes several screens to view the operating conditions of the unit. Scroll through the menu screens by using the  $\downarrow$   $\uparrow$  keys. Screens with a dashed line border are dependent upon an optional accessory and may not always appear.

TIME	DATE	UNIT##
		
TAP v1.04 GMYXX000X00		
STATUS LINE		

**THE INITIAL MENU SCREEN DISPLAYS THE PROGRAM VERSION, UNIT CODE AND STATUS LINE. THE STATUS LINE DISPLAYS WHICH MODE THE UNIT IS IN.**

Possible modes include:

- Initial Delay
- Opening Dampers
- Exhaust Fan Starting
- Supply Fan Starting
- System On
- Defrost Mode Active
- Sys On-Economizer
- Sys On-Heating
- Sys On-Cooling
- Sys On-Dehumidifying
- Sys On-Dehumid & Reheat
- Unoccupied-Unit Off
- Unoccupied-Heating
- Unoccupied-Cooling
- Manual Override
- Remote Off
- Press Alarm Button!!!

TIME	DATE	UNIT##
Supply Air:	000.0°F	
Outside Air:	000.0°F	
Cold Coil:	000.0°F	
Room:	000.0°F	
STATUS LINE		

**THE TEMPERATURES ON THIS SCREEN DISPLAY REAL TIME CONDITIONS FROM THE SENSORS LOCATED IN THE UNIT AND THE ROOM (IF INSTALLED).**

Energy Recovery	
Wheel:	000% Speed
Wheel Differential	
Pressure Is:	Normal
STATUS LINE	

**ENERGY RECOVERY WHEEL STATUS. (IF EQUIPPED)**

If equipped with an energy wheel, this screen will display the wheel speed. If the unit contains a wheel VFD, this screen will display the wheel speed being sent via the controller's wheel analog output.

If the unit does not contain an energy wheel VFD, 0% = OFF; 100% = ON.

If equipped with a frost control method, this screen will also display wheel pressure differential status. A pressure status of high is an indication of frost accumulation.

Cooling Status	
Cooling Control:	000%
Compressor	D 1 2
STATUS LINE	

**COOLING STATUS IS DISPLAYED, ALONG WITH COMPRESSOR OPERATION. (IF EQUIPPED)**

*This screen appears if a cooling option is provided.*

**Chilled Water:** The Cooling Control % is directly proportional to the 0-10 VDC output signal.

- 0% Cooling = 0 VDC
- 100% Cooling = 10 VDC

The cooling control output can be configured to DIRECT / REVERSE acting, along with the minimum and maximum output voltages by entering the **MANUFACTURER** menu.

**Packaged DX Cooling:** The Cooling Control displays internal cooling ramp as a percent. Compressor operation is displayed when engaged.

- D = Digital Scroll Compressor Operation
- 1 = First Staged Compressor Operation
- 2 = Second Staged Compressor Operation

**Heat Pump Cooling:** The Cooling Control displays internal cooling ramp as a percent. Compressor operation is displayed when engaged.

- 1 = First Staged Compressor Operation
- 2 = Second Staged Compressor Operation



Heating Status	
Heater Control:	000%
Hot Gas Reheat:	000%
Staged reheat is:	ON
Compressor:	1 2
STATUS LINE	

---

**HEAT AND REHEAT OPERATION IS DISPLAYED. (IF EQUIPPED)**

---

Heater Control displays the proportional percentage of the heater analog output.

**Electric Heater:** The Heater Control % is proportional to the 0-10 VDC signal being sent to the SCR controller, located in the electric heater control center.

0% Heating = 0 VDC - 0 kW output  
 100% Heating = 10 VDC - Max kW output

**Hot Water:** The Heater Control % is proportional to the 0-10 VDC signal being sent to the heating control valve (BY OTHERS). The heating control output can be configured to DIRECT / REVERSE acting, along with the minimum and maximum output voltages by entering the MANUFACTURER menu.

0% Heating = 0 VDC  
 100% Heating = 10 VDC

**Indirect Gas:** The Heater Control % is proportional to the 0-10 VDC signal being sent to the indirect gas furnace controller, located in the indirect gas control center. The first stage is on at 1% Heater Control. The furnace will then modulate proportionally from minimum to maximum capacity.

0% = 0 VDC - OFF  
 1% = 0 VDC - MINIMUM TURNDOWN ENABLED  
 1 - 100% = 0 - 10 VDC = FURNACE MODULATION

**Heat Pump Heating:** The Heater Control % displays internal heating ramp as a percent. Compressor operation is displayed when engaged.

- 1 = First Staged Compressor Operation
- 2 = Second Staged Compressor Operation

**Hot Gas Reheat:**

*If hot gas reheat is staged control:*

“Staged reheat is: ON/OFF” will indicate operation.

*If hot gas reheat is modulating bypass damper control:*

0% = OFF  
 1% - 100% = 4 - 10 VDC = AIRFLOW DAMPER MODULATION

*If hot gas reheat is modulating valve control:*

0% = OFF  
 1% - 100% = 0 - 10 VDC = HOT GAS REHEAT VALVE MODULATION

Preheat Status	
Preheat:	OFF
STATUS LINE	

---

**THIS SCREEN INDICATES ELECTRIC PREHEAT OPERATION. (IF EQUIPPED)**

---

*This screen appears if Electric Preheat frost control was provided.*



# Menu Overview

Press  to enter menus.

## On/Off Unit

On/Off Unit	Unit ON/OFF Control
Actual state: Off by DIG INPUT (ID4) Change to: SWITCH ON *Power ID4 to start...	Enable unit OnOff By digit input: Yes By BMS: No By scheduler: Yes

## Setpoint

Supply Set Point	Room Set Point	Supply Reset Limits	Supply Air Reset	Supply Set From BMS	Cold Coil Set Point	Set Point Source
is currently = 60°F This set pt is reset up/down by the DDC.	Local set pt: 72.0°F BMS set pt: ###.#°F Active set pt: ###.#°F	Supply Min: 55.0°F Supply Max: 90.0°F	Outside: 60.0°F --> Supply: 72.0°F 70.0°F --> 55.0°F	BMS interface: aaa.a°F Set pt min: 55.5°F Set pt max: 90.0°F	Normal Mode: 55.0°F Dehumidify: 50.0°F Active set pt: 55.0°F	Use local set point, or BMS interface set point? Local
Heater Lockout	Cooling Lockout	Dehumidification lock	Economizer Lockout	Supply air low limit	Defrost	UnOcc Fan Cycle Setup
Lockout heater when outside above: 70.0°F Hysteresis: 2.0°F	Lockout cooling when outside below: 55.0°F Hysteresis: 2.0°F	Lockout dehumidification until outside air is 10.0°F above cold coil set point.	Lockout econo when outside below: 40.0°F Hysteresis: 2.0°F	Alarm when supply is below: 35.0°F Alarm delay: 300s	Allow wheel defrost mode when outside is below: 5.0°F	Unit will energize to maintain unocc room set points. Heating: 65.0°F Cooling: 80.0°F Differential: 5.0°F

## Clock/Scheduler

Clock	Scheduler	Scheduler	Holiday #1
Day: Monday Date: MM/DD/YY Hour: ##:##	Number of schedules: 0 Holidays Holiday = unoccupied mode for 24 hours. Number of Holidays: ##	Schedule #: # Time On: ##:## Time Off: ##:## Days Enabled: MTWTFSS	Month: MM Day: DD Unoccupied for 24 hrs

## Input/Output

All I/O points are included. An example of each is shown.

Analog Input	Digital Input	Relay Output	Analog Output Y1
Outside Temperature Input B01: ###.#°F	Supply Fan DI 1 Status: (Closed) (Open)	Defrost Relay 1 Status: (Off) (On)	Wheel Output: ##.#vdc

## Data Logger

Hr:Min:Sec	MM/DD/YY
Alarm Description	###
Room T:	###
Discharge T:	###
Outside Air T:	###
Cold Coil T:	###
Unit Status	

## Board Switch

Board Switch	
Unit Address:	1
Switch to unit:	1
1 . . . . .	16
17 . . . . .	32

## Service

### a. Information

Information	Information
Accurex LLC	pCO Type: pCO3 Small
Code: XXXXXXXXX00	Total Flash: ###KB
Ver.: 1.04	Ram: ###KB
Manual/IOM: 475083	Built-in type:
Bios: 5.12	T Memory writes: ##
Boot: 4.03	Main Cycle: ###ms
	7.4 Cycle/s

### b. Overrides

Service Password	Control Loop Overrides	Energy Wheel Override	Wheel Preheat Override	Cooling Override	Heating Override
 Insert service password (PW1): 0000	Unit must be ON. To resume normal operation, cycle unit power.	Wheel Control: Auto Wheel: Off	Energy Recovery Wheel Preheat Control: Auto Preheater: Off	Cooling Control: Auto Cooling: 100%	Heating Control: Auto Heating: 100%
HotGas Reheat Override	I/O Manual Management	Analog Input	Digital Input	Relay Output	Analog Output Y1
Hot Gas Reheat Loop Control: Auto Reheat: 100%	END OF OVERRIDE MENU Press ENTER to go to I/O Manual Management menu.	Outside Temperature Manual Control B01: OFF Manual Position: # Value: ###.#°F	Supply Fan sw Manual DI 1: OFF Manual Position: CLOSED DI 1 Status: Open	Defrost Manual Relay 1: OFF Manual Position: OFF Relay 1 Status: OFF	Wheel Mode: Auto Manual Value: 0.0vdc Output: 0.0vdc



# Menu Overview



Press  to enter menus.

## Service



### c. BMS Config

<b>Service Password</b>  Insert service password (PW1): 0000	<b>BMS Configuration</b> Protocol: None BACnet Plugin? Yes	<b>MODBUS SETUP</b> Address: 1 Baudrate: 9600	<b>MSTP SETUP</b> Instance: 77000 Baudrate: 38400 MAC Addr: 0 MaxMasters: 127 MaxInfoFrames: 10	<b>TCP/IP SETUP</b> Instance: 77000 IP set by: DHCP IP: 172.016.000.001 Subnet: 255.255.255.000 Gateway: 192.168.001.001	<b>TCP/IP SETUP</b> DNS 1: ###.###.### DNS 2: ###.###.### Type: IP	<b>BACnet Read/Write</b> Function: Read Update? Yes *Cycle unit power to confirm write command.

### d. Service Settings

<b>Service Password</b>  Insert service password (PW1): 0000	<b>a. Working hour set</b> <b>MAINTENANCE HOURS</b> SYSTEM Run hours: 0000h Set Point: 0000h Reset to Zero? No	<b>b. Probe adjustment</b>		<b>Analog Input</b> Outside Temperature Input B01: ###.##°F Offset: 0.0°F Value: ###.##°F	<b>Analog Input</b> Discharge Temperature Input B02: ###.##°F Offset: 0.0°F Value: ###.##°F	<b>Analog Input</b> Cold Coil Temperature Input B03: ###.##°F Offset: 0.0°F Value: ###.##°F	<b>Analog Input</b> Room Temperature Input B04: ###.##°F Offset: 0.0°F Value: ###.##°F	<b>Probe Adjust</b> pCOe number: 1 Offset Ch 1: 0.0 Offset Ch 2: 0.0 Offset Ch 3: 0.0 Offset Ch 4: 0.0
	<b>c. Password/Defaults</b>	<b>User Default</b>  Insert new service password (PW1): 0000	<b>User Default settings</b>  Save? No Restore? No					

## Manufacturer

<b>Manufacturer Password</b>  Insert service password (PW1): 0000	<b>a. Configuration</b>		
	<b>Unit Code</b> Select DDC configuration code here. Code: GWXXXXXXXX00	<b>Unit Expansion Comm</b> Field Card Settings Baudrate: 19200 Stop bit: 2 Parity mode: NONE Timeout: 300ms	<b>Unit Expansion I/O</b> Enable Expansion: No
<b>b. I/O Configuration</b> <span style="float: right;">All I/O points are included An example of each is shown.</span>			
<b>Analog Input</b> Outside Temperature Channel:B1 Type: NTC Offset: ##.##°F Value: ##.##°F	<b>Digital Input</b> Supply Fan Channel: Action: ID1 Delay: OPEN 0s Open	<b>Relay Output</b> Defrost Channel: 1 Status: OFF	<b>Analog Output Config</b> Wheel Channel: Y1 Action: DIRECT Minimum: ##.##vdc Maximum: ##.##vdc
<b>c. Factory settings</b>			
<b>Factory Setup</b> Consult Factory Before Altering	<b>Economizer Controller</b> Integration: 300s Band: 20°F Econo ON/OFF times: Minimum ON: 300s Minimum OFF: 300s	<b>Supply Fan Cycling</b> Defrost setup Fan off time: 5min Fan on time: 30min	<b>Cooling Controller</b> Integration: 300s Band: 20°F
<b>Compressor Timers</b> Minimum ON: ###s Minimum OFF: ###s Between Stages: ###s	<b>Compressor Staging</b> Stage1: ON @ 50% OFF 0% Stage2: ON @100% OFF50%	<b>Heater Controller</b> Integration: 300s Band: 20°F	<b>Reheat Setup</b> Will heater be used for reheat during dehumidification? Reheat: Disable
<b>Hot Gas Setup</b> Hot gas reheat coil minimum on/off time: 10minutes	<b>Hot Gas Flush Setup</b> Cycle: 30minutes Duration: 1minutes	<b>Mod Hot Gas Setup</b> Minimum On: 4.0vdc Maximum On: 10.0vdc	<b>Supply Reset Control</b> Integration: 1200s Band: 10°F
<b>Damper Setup</b> Allow the dampers to open for: 10 seconds before starting the fans.	<b>Fan/Airflow Proving</b> Alarm delay: (inputs ID1 & ID5) 30s	<b>Fan Delay</b> Time delay between starting of supply & exhaust fans. Fan delay: 15s	<b>Wheel Rotation Sensor</b> Alarm delay: (input ID3) 30s
<b>Reheat Setup 2</b> Will heater be used for reheat along with hot gas? Heater: Disable	<b>Hot Gas Controller</b> Integration: 300s Band: 20°F	<b>Heat/Cool Delay</b> Time delay between heating, cooling &/or economizer modes. Delay: 180s	<b>Unoccupied Mode Setup</b> Type: CycleSupplyFan Source: Input ID6
<b>Temperature Scale</b> Select: Fahrenheit <b>Display Buzzer</b> Select: Disable	<b>d. Initialization</b>		
<b>Factory Settings</b>  Save? No Restore? No	<b>New Password</b>  Insert new manufacturer password (PW2): ####	<b>Initialization</b> DEFAULT INSTALLATION Erase user settings and install global default values: No	



## Menus

The controller is equipped with several menus to help guide users with altering program parameters. The following menus can be accessed by pressing the  key. To enter the desired menu, press the  key.

### A. On/Off Unit

The **On/Off Unit** menu allows the user to view the detailed On/Off status of the controller.

#### On/Off Unit

Actual state:  
Off by DIG INPUT (ID4)  
Change to: SWITCH ON  
\*Power ID4 to start...

The unit ships from the factory in a disabled state. To allow the unit to operate, the controller must receive a run command from digital input ID4. **Jumper unit terminals R - G to allow the unit to operate.**

**Actual State:** The controller may be in following On/Off states:

- a. Unit On - Unit is ON, functioning normally.
- b. Off by ALARM - Unit is OFF due to an alarm. View alarms by pressing ALARM button.
- c. Off by PLAN - Unit is OFF by pLAN network.
- d. Off by BMS - Unit is OFF by BMS command
- e. Off by SCHEDULER - Unit is OFF by internal Clock/Scheduler.
- f. Off by DIGITAL INPUT(ID4) - Unit is OFF by digital input 4 (ID4).
- g. Off by KEYPAD - Unit is commanded OFF by this screen.

**Change to (Switch Off/Switch On):** Enables user manually turn unit On/Off via display. Unit terminal G must have 24 VAC power to enable the unit.

#### Unit ON/OFF Control

Enable unit OnOff	
By digit input:	Yes
By BMS:	No
By Scheduler:	Yes

**THIS SCREEN ALLOWS THE USER TO ADJUST WHICH SYSTEM CONTROLS THE UNIT ON/OFF STATE.**

**Digital Input:** Default to YES. Unit terminal G must have 24 VAC power to enable the unit.

The user can also use the BMS or internal time clock to command the unit On/Off state. If scheduling is desired, go to the Clock/Scheduler menu to set a schedule.

**BMS:** YES allows BMS to control unit On/Off state.

**Scheduler:** YES allows internal scheduler (time clock) for unit On/Off control.

### B. Setpoint

The **Setpoint** menu allows the user to view and adjust temperature related parameters.

#### Supply Set Point

is currently = 60°F

This set pt is reset up/down by the DDC

**THIS SCREEN DISPLAYS THE CURRENT SUPPLY AIR SET POINT.**

*This screen does not appear if a BMS is directly setting the supply air set point.*

This screen displays the current supply air set point, determined by the controller. The supply set point is reset either by outdoor air temperature, or room temperature if installed. The user may also directly control the supply air set point. To activate the BMS set point capability, go to the **Set Point Source** screen in this menu.

If a room temperature sensor is connected to the controller, the supply air temperature is reset to achieve the room temperature set point. The “local” room temperature set point can be set via the controller (see **Room Set Point** screen). Otherwise, the BMS can directly input the desired room set point. To activate the BMS set point capability, go to the **Set Point Source** screen in this menu.

#### Room Set Point

Local set pt:	72.0°F
BMS set pt:	70.0°F
Active set pt:	70.0°F

**THIS SCREEN DISPLAYS THE ROOM SET POINT.**

*This screen only appears if a room sensor is wired into controller terminals B4 and BC4.*

The unit will reset the supply air temperature to maintain the local set point. If a BMS is interfaced with the controller, the user has the capability to directly input the desired Room Set Point though the BMS. The screen will show a BMS set point and an Active set point. The active set point is the room temperature the controller is currently trying to maintain.



### Supply Reset Limits

Supply Min: 55.0°F  
Supply Max: 90.0°F

### Supply Air Reset

Outside: Supply  
60.0°F --> 72.0°F  
70.0°F --> 55.0°F

### Supply Set From BMS

BMS interface: ##.##°F  
Set pt min: 55.5°F  
Set pt max: 90.0°F

### Cold Coil Set Point

Normal Mode: 55.0°F  
Dehumidify: 50.0°F  
Active set pt: 55.0°F

### Heater Lockout

Lockout heater when outside above: 70.0°F  
Hysteresis: 2.0°F

### Cooling Lockout

Lockout cooling when outside below: 55.0°F  
Hysteresis: 2.0°F

**THIS SCREEN DISPLAYS THE MINIMUM AND MAXIMUM SUPPLY AIR TEMPERATURE LIMITS.**

*This screen only appears if the unit is connected to a room temperature sensor.*

The supply air temperature will be controlled within the Supply Min and Supply Max limits to maintain room temperature set point.

**THESE PARAMETERS DICTATE THE OPERATION OF THE OUTDOOR AIR RESET FUNCTION.**

*This screen does not appear when a room temp sensor is wired to the controller.*

The controller monitors the outdoor air temperature and adjusts the desired supply temperature accordingly. For example, when the outdoor air is below 60°F, the controller will change the Supply set point to 72°F. If the outdoor air is above 70°F, the controller will change the Supply set point to 55°F. If the outdoor air temperature is between 60°F and 70°F, the Supply set point changes according to the outdoor air reset function. A visual representation of the outdoor air reset function is shown below.

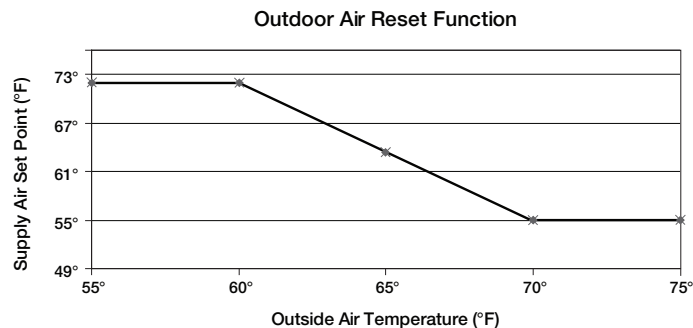

**THIS SCREEN DISPLAYS THE SUPPLY AIR SET POINT AS SET BY A BMS.**

*This screen appears if the unit has BMS communications and set point source is set to BMS.*

See Set Point Source screen in this menu to allow BMS to determine set point.

**THIS SCREEN DISPLAYS THE TEMPERATURE SET POINTS FOR THE COOLING COIL.**

*This screen only appears if the unit is equipped with cooling.*

The Normal mode set point is the after coil temperature the unit will maintain under standard operation, when in cooling. If a humidistat was provided with the unit, the Dehumidify set point is the temperature the cooling coil will discharge on a call for dehumidification. The Active set point is the cooling coil discharge temperature the unit is currently trying to maintain.

**THE CONTROLLER WILL LOCKOUT HEATING WHEN THE OUTDOOR AIR TEMPERATURE IS ABOVE THE HEATING LOCKOUT SET POINT. (FACTORY DEFAULT = 70°F)**

*This screen only appears if the unit the unit is equipped with heating.*

There is a built in hysteresis of 2°F which prevents the heating from short cycling. The hysteresis is similar to a dead-band above and below the lockout set point. (Example: If Lockout = 70°F, heating is locked out above 72°F and enabled below 68°F outside air temperature.)

**THE CONTROLLER WILL LOCKOUT COOLING WHEN THE OUTDOOR AIR TEMPERATURE IS BELOW THE COOLING LOCKOUT SET POINT. (FACTORY DEFAULT = 55°F)**

*This screen only appears if the unit the unit is equipped with cooling.*

There is a built in hysteresis of 2°F which prevents the cooling from short cycling. The hysteresis is similar to a dead-band above and below the lockout set point. (Example: If Lockout = 55°F, cooling is locked out below 53°F and enabled above 57°F outside air temperature.)



### Dehumidification lock

Lockout dehumidification until outside air is 10.0°F above cold coil set point.

### Economizer Lockout

Lockout econo when outside below: 40.0°F  
Hysteresis 2.0°F

### Supply air low limit

Alarm when supply is below: 35.0°F  
Alarm delay: 300s

### Defrost

Allow wheel defrost mode when outside is below: 05.0°F

### UnOcc Fan Cycle Setup

Unit will energize to maintain unocc room set points.  
Heating: 65.0°F  
Cooling: 80.0°F  
Differential: 5.0°F

### Set Point Source

Use local set point, or BMS interface set point? Local

---

**THIS SCREEN DISPLAYS THE TEMPERATURE DIFFERENCE AT WHICH THE DEHUMIDIFICATION MODE IS LOCKED OUT. (FACTORY DEFAULT = 10°F)**

---

*This screen only appears if the unit is equipped with cooling.*

This setting prevents the unit from operating in dehumidification mode when the outdoor air conditions are relatively cool. **Example:** If the cold coil set point is 55°F, dehumidification mode cannot operate until the outdoor air is at least 65°F.

---

**ECONOMIZER LOCKOUT PREVENTS THE UNIT FROM GOING INTO ECONOMIZER MODE WHEN THE OUTDOOR AIR CONDITIONS ARE TOO COLD.**

---

*This screen only appears if economizer was provided with the unit.*

The lockout prevents outdoor air from: (1) entering the space at too cold of a temperature or (2) entering heating or cooling coils at conditions that could freeze the coils. Built-in hysteresis of 2°F. The hysteresis is similar to a dead-band above and below the lockout set point. **Example:** If Lockout = 40°F, economizer is locked out below 38°F and enabled above 42°F outside air temperature.)

---

**THIS SCREEN DISPLAYS THE LOW SUPPLY AIR TEMPERATURE LIMIT.**

---

If the unit supply air temperature falls below Supply Air Low Limit for a period of Alarm Delay, the unit will shut down and an alarm will be signaled. The purpose of the supply low limit is to protect the building and contents from cold supply air. It is NOT designed to protect the air-handling unit.

If the unit does not have chilled water (CW) or hot water (HW) coils, it should not need additional protection from freezing. If the unit does have CW or HW coils, field provided coil freeze protection may be necessary.

---

**THIS SCREEN DISPLAYS THE TEMPERATURE AT WHICH THE UNIT WILL ENABLE FROST CONTROL MODE IF NECESSARY. (FACTORY DEFAULT = 5°F)**

---

*This screen only appears if the unit has an energy recovery wheel and a frost control method was provided with the unit.*

Upon sensing a high differential pressure across the energy wheel, the unit will go into defrost if the outside air temperature is below this temperature setting.

---

**THIS SCREEN DISPLAYS THE ROOM SET POINTS FOR HEATING AND COOLING OPERATION DURING UNOCCUPIED MODE.**

---

*This screen only appears if the unoccupied mode is set to “Cycle on Room” instead of “Unit Off”. A room temp sensor must be wired into the controller. For energy recovery units, a Night Set-Back Damper must be installed.*

In unoccupied mode when the temperature falls below the room Heating set point, the supply fan and heating will turn on. If the unit is an Energy Recovery unit, the Night Set-Back Damper will also open. The unit will discharge the Supply Max temperature per the Supply Reset Limits screen, until the room set point is satisfied. Unit will then shut down. When the temperature rises above the Cooling set point, the unit will discharge the Supply Min temperature per the Supply Reset Limits screen until the room temperature set point is satisfied. Unit will then shut down.

The differential acts as a hysteresis to keep the heating and cooling from cycling too often. For example, on a call for heating, the unit turns on at 60°F and turns off at 65°F. For cooling, the unit turns on at 85°F and turns off at 80°F.

---

**USERS CAN CHOOSE EITHER THE CONTROLLER OR THE BMS TO DETERMINE SUPPLY AIR SET POINT DURING OPERATION.**

---

*This screen only appears if the controller was supplied with BMS capability.*

Local means the controller set point will be used during operation. (Outdoor Air Reset or Room Reset)

BMS means that the BMS set point will be used during operation.



## C. Clock/Scheduler

The **Clock/Scheduler** menu allows the user to view and alter the time and date. The user can also add up to seven schedules for occupancy requirements.

Clock	
Day:	Monday
Date:	01/31/10
Hour:	15:30

Scheduler	
Number of schedules:	0
Holidays	
Holiday = unoccupied mode for 24 hours.	
Number of Holidays:	0

Scheduler	
Schedule #:	#
Time On:	07:00
Time Off:	05:00
Days Enabled:	MTWTFSS

Holiday #1	
Month:	MM
Day:	DD
Unoccupied for 24 hrs	

**THE CLOCK SCREEN ALLOWS THE USER TO ADJUST THE TIME AND DATE.**

**THIS SCREEN ALLOWS THE USER TO ADD THE NUMBER OF UNOCCUPIED SCHEDULES AND HOLIDAYS.**

The Number of Schedules corresponds to the number of unoccupied periods the user wishes to add. By setting the number of schedules to a value greater than zero, the unoccupied mode will automatically be set to time clock.

A holiday is a single occurrence in which you would like the unit to be unoccupied for 24 hours. A maximum of 15 holidays can be set. Holidays must be reconfigured each year.

**THIS SCREEN ALLOWS THE USER TO ADJUST SCHEDULES.**

*This screen only appears if a Schedule was added in the screen above.*

The program supports up to seven separate schedules. Each schedule will require the user to enter a Time On, Time Off and which days the schedule is applicable for.

**THIS SCREEN ALLOWS THE USER TO SET HOLIDAY DATES (IF ENABLED).**

*This screen only appears if Holidays are enabled.*

The internal time clock will go into unoccupied mode as long as the date is equal to the holiday date (always a 24 hour period).

## D. Input/Output

The **Input/Output** menu allows the user to quickly view the status of the controller inputs and outputs.

Analog Input	
Outside Temperature Input B01:	75.0°F

To manually control I/O values, go to the **Service menu > Overrides**. Similar screens appear for all controller inputs and outputs.

## E. Data Logger

The **Data Logger** menu allows the user to view past alarms.

13:21:04 10/05/10	
OA Sensor	
Room T:	70.0
Discharge T:	65.0
Outside Air T:	-623.3
Cold Coil T:	55.0
System Off	

**THIS SCREEN IS AN EXAMPLE OF A RECORDED ALARM.**

The unit conditions are displayed for past alarm events. The date, time, temperatures and unit status are recorded.

To clear recorded alarms, press  and  simultaneously.



## F. Board Switch

The **Board Switch** menu allows the user to jump between different controllers with a remote display. This requires a remote display, along with additional controllers, set-up in a pLAN network. A pLAN can consist of up to 32 devices, in different combinations, but a maximum of 31 controllers.

Board Switch	
Unit Address:	1
Switch to unit:	1
1 . . . . .	16
17 . . . . .	32

**WHEN VIEWING THIS SCREEN FROM A REMOTE DISPLAY, THE USER IS ABLE TO CHANGE WHICH CONTROLLER'S MENU SHOULD BE DISPLAYED.**

**Unit Address:** The pLAN address of the controller the display is currently accessing.

**Switch to unit:** The pLAN address of the controller the display would like to access.

## G. Service

The **Service** menu allows the user to access several sub-menus regarding controller information, controller overrides, operating hours, BMS configuration, I/O manual management and Probe Adjustment. The user can also change the default Service Password (1000) by accessing the **Service Settings** sub-menu. By accessing the **BMS Config** sub-menu, the user can adjust BMS protocol settings (BACnet, LonWorks, Modbus).

G.  Service	
a. Information	

**ENTERING THE INFORMATION SUB-MENU WILL DISPLAY INFORMATION ABOUT THE CONTROLLER AND THE PROGRAM LOADED ON THE CONTROLLER.**

Information	
Accurex LLC	
Code: GMY10000X00	
Ver.: 1.04	06/13/11
Manual:	475083
Bios: 5.12	11/17/10
Boot: 4.03	07/03/06

**Code:** Controller setup code determines functionality of program. When contacting the factory, please reference this code.

G.  Service	
b. Overrides	

The **Overrides** menu is for start-up, commissioning and troubleshooting. This menu allows the user to override the control loops. If further control is required, the user can also manually control the controller inputs and outputs. To access the **Overrides** sub-menu, enter the service password (Default=1000).

Control Loop Overrides	
Unit must be ON.	
To resume normal operation, cycle unit power.	

To manually override a control loop, the unit must be ON. In each respective screen, change the control from AUTO to MANUAL.

To resume normal operation after overriding the controller, simply cycle power to the unit.

Energy Wheel Override	
Wheel Control:	Auto
Wheel:	OFF

**THIS SCREEN ALLOWS THE USER TO OVERRIDE THE ENERGY WHEEL OPERATION.**

*This screen only appears if the unit is equipped with a non-VFD operated energy wheel.*

When the Wheel Control is in the MANUAL mode, use the arrow buttons to turn the wheel ON or OFF.

Energy Wheel Override	
Wheel Control:	Auto
Wheel:	100%

**THIS SCREEN ALLOWS THE USER TO OVERRIDE THE ENERGY WHEEL OPERATION.**

*This screen only appears if the unit is equipped with a VFD operated energy wheel.*

When the Wheel Control is in the MANUAL mode, use the arrow buttons to alter the wheel %. This is directly proportional to a 0 - 10 VDC signal being sent to the energy wheel VFD.



### Wheel Preheat Override

Energy Recovery Wheel  
Preheat Control: Auto  
Preheater: OFF

### Cooling Override

Cooling Control: Auto  
Cooling: 100%

### Heating Override

Heating Control: Auto  
Heating: 100%

### HotGas Reheat Override

Hot Gas Reheat  
Loop Control: Auto  
Reheat: OFF

### HotGas Reheat Override

Hot Gas Reheat  
Loop Control: Auto  
Reheat: 100%

**THIS SCREEN ALLOWS THE USER TO OVERRIDE THE ENERGY RECOVERY WHEEL PREHEATER.**

*This screen only appears if an electric preheat frost control was provided with the unit.*

**THIS SCREEN ALLOWS THE USER TO OVERRIDE THE COOLING OPERATION.**

*This screen only appears if a cooling operation was provided with the unit.*

When the Cooling Control is in the MANUAL mode, use the arrow buttons to vary the cooling output.

**Chilled Water:** The Cooling % is directly proportional to the 0 - 10 VDC output signal.

0% Cooling = 0 VDC; 100% Cooling = 10 VDC

**Packaged Cooling and Heat Pump:** The Cooling % displays compressor engagement as a percent. The compressors are subject to the minimum On/Off times and Heating/Cooling Lockouts. Compressors engage in sequence as described in the Compressor Staging screen in the **Manufacturer > Factory Settings** menu.

**THIS SCREEN ALLOWS THE USER TO OVERRIDE THE HEATING OPERATION.**

*This screen only appears if a heating operation was provided with the unit.*

When the Heating Control is in the MANUAL mode, use the arrow buttons to vary the heating output.

**Electric Heater:** The Heater Control % is proportional to the 0-10 VDC signal being sent to the SCR controller, located in the electric heater control center.

0% Heating = 0 VDC - 0 kW output

100% Heating = 10 VDC - Max kW output

**Hot Water:** The Heater Control % is proportional to the 0-10 VDC signal being sent to the heating control valve (BY OTHERS).

0% Heating = 0 VDC

100% Heating = 10 VDC

**Indirect Gas:** The Heater Control % is proportional to the 0-10 VDC signal being sent to the indirect gas furnace controller, located in the indirect gas control center. The first stage is on at 1% Heater Control. The furnace will then modulate proportionally from minimum to maximum capacity. The furnace is subject to minimum On/Off times and Heating Lockouts.

0% = 0 VDC – OFF

1% = 0 VDC – MINIMUM TURNDOWN ENABLED

1 - 100% = 0 - 10 VDC = FURNACE MODULATION

**Heat Pump:** The Heating % displays compressor engagement as a percent. The compressors are subject to the minimum On/Off times and Heating Lockouts. Compressors engage in sequence as described in the Compressor Staging screen in the **Manufacturer > Factory Settings** menu.

**THIS SCREEN ALLOWS THE USER TO OVERRIDE THE HOT GAS REHEAT OPERATION.**

*This screen only appears if On/Off hot gas reheat option was provided with the unit.*

When the Hot Gas Reheat Loop Control is in the MANUAL mode, use the arrow buttons to turn the hot gas reheat ON or OFF.

**THIS SCREEN ALLOWS THE USER TO OVERRIDE THE HOT GAS REHEAT OPERATION.**

*This screen only appears if modulating hot gas reheat option was provided with the unit.*

When the Hot Gas Reheat Loop Control is in the MANUAL mode, use the arrow buttons to vary the reheat output.



## I/O Manual Management

END OF OVERRIDE MENU

Press ENTER to go to I/O Manual Management menu.

## Analog Input

Outside Temperature Manual Control B01: ON  
Manual Position 290  
Value 84.2°F

## G. Service

c. BMS Config

## BMS Configuration

Protocol: BACnet MSTP  
BACnet Plugin? YES

## MODBUS SETUP

Address: 1  
Baudrate 9600

### ***THIS SCREEN ALLOWS THE USER TO ENTER THE I/O MANUAL MANAGEMENT MENU.***

The **Manual Management** menu allows the user to manually control the I/O of the controller. The user can manually input values for the analog inputs and digital inputs. The user can also manually control the analog outputs and digital outputs. **EXTREME CAUTION should be used when manually controlling the I/O.** It is highly recommended that manual control of the I/O is done only with factory assistance. The controller's safeties and lockouts are bypassed by this manual management and should only be used as a troubleshooting feature. If the controller is powered down, I/O Manual Management is reset to off. Therefore, if using this troubleshooting feature, the best way to clear manually input values is to power down the controller.

### ***THIS SCREEN IS AN EXAMPLE OF A MANUALLY MANAGED TEMPERATURE ANALOG INPUT.***

To manually control an analog input, change Manual Control to ON. Move cursor to Manual position and alter value. The altered value will be displayed below.

Similar screens exist for the remaining I/O. Contact the factory for more details.

The BMS Config menu allows the user to view and alter BMS protocol settings. If the BMS protocol is BACnet or Modbus, additional screens allow further configuration. See below for details. To access the BMS Config sub-menu, enter the service password (Default=1000).

### ***THIS SCREEN ALLOWS THE USER TO SELECT THE BMS PROTOCOL. ALL BMS PROTOCOLS REQUIRE A COMMUNICATIONS CARD INSTALLED IN THE SERIAL CARD PORT, LOCATED ON THE FACE OF THE CONTROLLER.***

If the protocol is BACnet MSTP or BACnet IP/Eth, the user can change common BACnet parameters via the controller. The BACnet Plugin must be set to YES.

### ***THIS SCREEN ALLOWS THE USER TO ADJUST MODBUS PARAMETERS.***

*This screen only appears if the selected BMS protocol is set to Modbus.*

The address is the Modbus address of the card installed in the SERIAL CARD port located on the face of the controller. (Factory Default Address = 1).

The Baud Rate should be set to the BMS baud rate (Factory Default Baud Rate is 9600).



### MSTP SETUP

Instance:	77000
Baudrate	38400
MAC Addr:	0
MaxMasters:	127
MaxInfoFrames:	20

### BACnet Read/Write

Function:	Read
Update?	Yes

\*Cycle unit power to confirm write command.

### TCP/IP SETUP

Instance:	77000
IP set by:	DHCP
IP:	128.2.104.134
Subnet:	255.255.000.000
Gateway:	128.2.0.12

### TCP/IP SETUP

DNS 1:	193.168.001.001
DNS 2:	193.168.001.001
Type: IP	

### BACnet Read/Write

Function:	Read
Update?	Yes

\*Cycle unit power to confirm write command.

### ***THIS SCREEN ALLOWS THE USER TO ADJUST BACNET MSTP PARAMETERS.***

*This screen only appears if the selected BMS protocol is set to BACnet MSTP and BACnet Plugin = YES.*

If a BACnet MSTP card has been installed, the default parameters can be changed via the controller display. Factory settings are shown in the screen to the left.

#### To view current parameters:

1. Power on controller and allow several minutes to initialize.
2. Go to **BMS Config** menu and view BACnet Read/Write screen.
3. Change *Function* to *Read* and *Update?* to *YES*.

Current BACnet MSTP parameters should now be displayed in the BACnet MSTP SETUP screen. If all values appear to be zeros, consult the factory. (Make sure you have allowed several minutes for the controller to initialize).

*\*Values may appear to be zero prior to setting the Function to READ.*

#### To change BACnet MSTP parameters:

1. Power on controller and allow several minutes to initialize.
2. Go to **BMS Config** menu and view MSTP SETUP screen.
3. Move cursor to desired parameter by pressing the  $\downarrow$   $\uparrow$  buttons. Press  $\leftarrow$  to select the parameter to change. Press the  $\downarrow$   $\uparrow$  buttons to adjust the parameter. Press  $\rightarrow$  to save adjusted value.
4. Once desired parameters have been entered, go to BACnet Read/Write screen. Change *Function* to *Write* and *Update?* to *YES*.
5. Reboot the controller by cycling power to the unit. Allow several minutes for the controller to initialize.
6. View MSTP parameters. If changed values did not save, contact the factory.

### ***THIS SCREEN ALLOWS THE USER TO ADJUST BACNET IP PARAMETERS.***

*This screen only appears if the selected BMS protocol is set to BACnet IP/Eth and BACnet Plugin = YES.*

If a BACnet IP card has been installed, the default parameters can be changed via the controller display. **The card is in DHCP mode from the factory.** Once communication is established, the user can enter static IP parameters.

#### To view current parameters:

1. Power on controller and allow several minutes to initialize.
2. Go to **BMS Config** menu and view BACnet Read/Write screen.
3. Change *Function* to *Read* and *Update?* to *YES*.

Current BACnet IP parameters should now be displayed in the BACnet TCP/IP SETUP screen. If all values appear to be zeros, consult the factory. (Make sure you have allowed several minutes for the controller to initialize).

*\*Values may appear to be zero prior to setting the Function to READ.*

#### To change BACnet TCP/IP parameters:

1. Power on the controller and allow several minutes to initialize.
2. Go to **BMS Config** menu and view TCP/IP SETUP screen.
3. Move cursor to desired parameter by pressing the  $\downarrow$   $\uparrow$  buttons. Press  $\leftarrow$  to select the parameter to change. Press the  $\downarrow$   $\uparrow$  buttons to adjust the parameter. Press  $\rightarrow$  to save adjusted value.
4. Once desired parameters have been entered, go to BACnet Read/Write screen. Change *Function* to *Write* and *Update?* to *YES*.
5. Reboot the controller by cycling power to the unit. Allow several minutes for the controller to initialize.
6. View TCP/IP parameters. If changed values did not save, contact the factory.



Unit BMS Control	
Unit Start/Stop:	No
Temp Setpoint:	Local
Occupancy:	Input ID6

**THIS SCREEN ALLOWS THE USER TO QUICKLY ENABLE THE BMS TO CONTROL UNIT OPERATION.**

*This screen appears if the unit is equipped with a BMS communication card.*

The factory default configuration is for a non-BMS controlled unit. To allow the BMS to start/stop the unit, change set point and occupancy, alter the parameters on this screen.

BMS Writable Points	
TempSetpoint:	78.0°F
Start/Stop:	Stop
Reset Alarms:	No
Occupancy:	Occ

**THIS SCREEN ALLOWS THE USER TO VIEW THE STATUS OF THE WRITABLE BMS POINTS.**

View the status of each point to confirm BMS communication.

**G.  Service**

- d. Service Settings 
  - a. Working hour set
  - b. Probe adjustment
  - b. Password/Defaults

The **Service Settings** menu allows the user to change the default Service Password (1000), save and restore default parameters, and adjust probe values.

MAINTENANCE HOURS	
SYSTEM	
Run hours:	0000h
Set Point:	0000h
Reset to Zero?	No

**THIS SCREEN ALLOWS THE USER TO VIEW UNIT RUN HOURS, AND ALTER SET POINTS FOR MAINTENANCE.**

**Run hours:** The amount of time in hours that the unit has been powered.

**Set Point:** The amount of running time in hours before a maintenance alarm should occur.

**Reset to Zero:** Reset the measured amount of run time.

Analog Input	
Outside Temperature Input B01	
Offset:	0.0°F
Value:	70.5°F

**THE PROBE ADJUSTMENT MENU ALLOWS THE USER TO CALIBRATE SENSOR PROBES WITH AN OFFSET VALUE.**

*Similar screens are available for remaining sensor probes.*

**User Default**



Insert new service password (PW1): 1000

**THIS SCREEN ALLOWS THE USER TO CHANGE THE SERVICE LEVEL PASSWORD (PW1)**

**User Default Settings**



Save? No  
Restore? No

**THIS SCREEN ALLOWS THE USER TO SAVE AND RESTORE THE DEFAULT PARAMETERS STORED IN MEMORY.**

If the user would like to save their settings, move the cursor to the **SAVE** position and change to **YES**. This will save all of the current parameters into memory as Service Settings. If the user would like to restore to these values at some point in the future, moving the cursor to the **RESTORE** position, and selecting **YES** will restore the controller to the user saved defaults.



## H. Manufacturer

### a. Configuration



Configuration menu allows the user to change the setup code for the unit, enable Scheduling, Holidays, expansion I/O and change Field Card settings. Users are welcomed to enable Scheduling and Holidays. However, code changes and expansion I/O enabling are to be done under factory advice only!

Unit Code	
Select DDC configuration code here.	
Code:	GWY1X000X00

Configuration	
Modbus settings	
Baudrate:	19200
Stop bit:	2
Parity mode:	None
Timeout:	300ms

Unit Expansion I/O	
Enable Expansion:	No

Controller pLAN Setup	
Current pLAN Addr:	1
New pLAN Addr:	1

## H. Manufacturer

### b. I/O Configuration



The I/O Configuration menu allows adjustment of all controller inputs and outputs. This menu is similar to the Probe Adjustment menu, except that it additionally allows adjustment of the factory default 'normal' states of the digital inputs and the direction of the analog outputs. Additionally, it allows adjustment of the physical location of each I/O. **ADJUSTMENT OF I/O PHYSICAL LOCATION MUST ONLY BE DONE UNDER FACTORY GUIDANCE! IMPROPER ADJUSTMENT MAY RESULT IN SYSTEM DAMAGE!**

Analog Input	
Outside Temperature Channel:B1 Type:	Normal NTC
Offset:	0.0°F
Value:	70.5°F

This is an example of an analog input configuration screen.

In the I/O configuration screens, the user can alter the physical location and type of each point.

Similar configuration screens appear for the remaining I/O.

Alarm Time Delay	
Outside Temperature Input B01:	72.0°F
Out of Range Alarm	
Power Delay:	30s
Run Delay:	30s

Digital Input	
Remote On/Off Channel:	ID4
Action:	CLOSED
Delay:	0s
	Open

Relay Output	
Defrost Channel:	1
Status:	OFF

Analog Output Config	
Cool:	
Channel:	Y3
Action:	DIRECT
Minimum:	0.0vdc
Maximum:	10.0vdc

#### **THIS SCREEN DISPLAYS AND ALLOWS ADJUSTMENT OF THE UNIT CODE.**

This code is set from the factory to operate the components selected with the unit. When troubleshooting, refer to the wiring diagram sent with the unit (located on the control center door) to verify the Unit Code is correct. The code will be listed on the wiring diagram.

#### **THIS SCREEN ALLOWS THE USER TO ALTER THE FIELD CARD MODBUS SETTINGS.**

The FIELD CARD is used for peripheral device control (pCOe Expansion Module).

The Modbus settings should only be changed with factory guidance.

#### **THIS SCREEN ALLOWS THE USER TO ENABLE ADDITIONAL I/O POINTS.**

Unit I/O expansion requires the installation of a pCOe and Field Card. Please contact the factory for more information.

Enabling the I/O expansion allows the user to add the following points for monitoring:

- Four analog inputs (0/1vdc, 0/5vdc, 0/20mA, 4/20mA, NTC Temp)
- One analog output (0/10vdc)
- Four digital inputs
- Four digital outputs

The additional I/O points available on the pCOe expansion module allow the user to monitor and control the additional points over the BMS and user display.

#### **THIS SCREEN ALLOWS THE USER TO VIEW AND CHANGE THE CONTROLLER pLAN ADDRESS.**

A pLAN (pCO Local Area Network) is a Carel proprietary local area network, allowing the user to connect multiple controllers to one remote display panel. Each controller on a pLAN must have a unique address.

This address is only applicable for units connected on a pLAN. For BACnet, LonWorks or Modbus parameters, go to **Service > BMS Config**.



## H. Manufacturer

### c. Factory Settings

The **Factory Settings** menu allows adjustment of parameters that are critical for proper unit operation. Adjustment of these parameters is only recommended with factory guidance. To access the **Factory Settings** menu, enter the manufacturer password (Default=1000).

#### Economizer Controller

Integration	300s
Band:	20°F
Econo ON/OFF times:	
Minimum ON:	300s
Minimum OFF:	300s

#### **THIS SCREEN ALLOWS THE ADJUSTMENT OF PARAMETERS FOR THE ECONOMIZER FUNCTION.**

*This screen only appears if an economizer mode was selected with the unit.*

The controller utilizes a PI loop control for the economizer function. This allows for less sporadic changes in supply temperature, resulting in a smooth reaction to changing conditions. To speed up reaction time, decrease the integration time. For slower reaction time, increase the integration time. When making adjustments, make them in small increments and test the system to determine if the new setting is adequate prior to further adjustment. The band is the range that the integration will occur between. Range of integration = Supply set point ± Band.

The minimum ON and OFF times prevent the energy wheel from short cycling during economizer mode.

#### Supply Fan Cycling

Defrost setup	
Fan off time:	5min
Fan on time:	30min

#### **THIS SCREEN ALLOWS THE ADJUSTMENT THE TIMED EXHAUST FROST CONTROL ON/OFF TIMES.**

*This screen only appears if Timed Exhaust Frost Control was provided with the unit.*

The ON/OFF times prevent the build up of frost when the unit is in Timed Exhaust Frost Control mode.

#### Cooling Controller

Integration:	300s
Band:	20°F

#### **THIS SCREEN ALLOWS ADJUSTMENT OF THE COOLING PI CONTROL LOOP.**

*This screen only appears if cooling option was provided with the unit.*

The controller utilizes a PI loop control for cooling. This allows for less sporadic changes in supply temperature, resulting in a smooth reaction to changing conditions. To speed up reaction time, decrease the integration time. For slower reaction time, increase the integration time. When making adjustments, make them in small increments and test the system to determine if the new setting is adequate prior to further adjustment. The band is the range that the integration will occur between.

#### Compressor Setup

# of stages:	2
Rotation:	LIFO

#### **THIS SCREEN DISPLAYS THE NUMBER OF STANDARD COMPRESSOR STAGES PROVIDED WITH THE UNIT AND SHOWS THE ROTATION SEQUENCE.**

*This screen only appears if DX cooling was provided with the unit.*

The number of stages displayed is equal to the number of non-modulating compressors. Factory default compressor rotation is LIFO (Last In, First Out). Compressor rotation can not be changed on units equipped with: Digital Scrolls, Hot Gas Reheat or Heat Pump.

#### Digital Compressor

Minimum OFF:	1.0vdc
Minimum ON:	1.9vdc
Maximum:	5.0vdc
Delay OFF:	60s
Max Power Start:	120s

#### **THIS SCREEN DISPLAYS THE DIGITAL SCROLL COMPRESSOR PARAMETERS.**

*This screen only appears if a digital scroll compressor was provided with the unit.*

**Minimum OFF:** This is the minimum voltage the controller outputs when the digital scroll is disabled/OFF

**Minimum ON:** This is the minimum voltage the controller outputs when the digital scroll is enabled/ON.

**Maximum:** This is the maximum voltage the controller outputs when the digital scroll is operating at full capacity.

**Delay OFF:** Delays shutting off digital scroll by this duration.

**Max Power Start:** Upon starting, the digital scroll will run at full capacity for this duration. This ensures the refrigeration system is at proper conditions, prior to modulation.



### Compressor Timers

Minimum ON: 30s  
Minimum OFF: 180s  
Between Stages: 30s

### Compressor Staging

Stage1: ON @ 50% OFF 0%  
Stage2: ON @ 100% OFF 50%

### Heater Controller

Integration: 300s  
Band: 20°F

### Reheat Setup

Will heater be used for reheat during dehumidification?  
Reheat: Disable

### Reheat Setup 2

Will heater be used for reheat along with hot gas?  
Heater: Disable

### Hot Gas Controller

Integration: 300s  
Band: 20°F

### Hot Gas Setup

Hot gas reheat coil minimum on/off time: 10minutes

### **THIS SCREEN DISPLAYS THE COMPRESSOR MINIMUM ON AND OFF TIMES.**

*This screen only appears if DX cooling was provided with the unit.*

The compressor minimum ON/OFF times prevents short cycling of the compressors.

### **THIS SCREEN DISPLAYS WHEN EACH COMPRESSOR IN A SINGLE OR DUAL STAGE DX UNIT WILL ENGAGE/DISENGAGE.**

*This screen only appears if DX cooling was provided with the unit.*

Each compressor will engage and disengage based upon the percentage of cooling capacity the controller needs.

### **THIS SCREEN ALLOWS ADJUSTMENT OF THE HEATING PI CONTROL LOOP.**

*This screen only appears if heating option was provided with the unit.*

The controller utilizes a PI loop control for heating. This allows for less sporadic changes in supply temperature, resulting in a smooth reaction to changing conditions. To speed up reaction time, decrease the integration time. For slower reaction time, increase the integration time. When making adjustments, make them in small increments and test the system to determine if the new setting is adequate prior to further adjustment. The band is the range that the integration will occur between.

### **THIS SCREEN ALLOWS THE USER TO ENABLE THE HEATER FOR REHEAT PURPOSES.**

*This screen appears if a heating option was provided and the unit does NOT have hot gas reheat OR a heat pump.*

If it is desired that the heater be used to reheat the air off of the cooling coil when in dehumidification, adjust this screen so the heater is ENABLED for reheat.

### **THIS SCREEN ALLOWS THE USER TO ENABLE THE HEATER TO PROVIDE REHEAT IN ADDITION TO HOT GAS REHEAT**

*This screen appears if hot gas reheat and a heating option was provided (except heat pump).*

Setting the heater parameter to enable allows the heating option to provide additional reheat beyond what the hot gas reheat can provide. This would typically only be used if the supply air temperature is too cold.

### **THIS SCREEN ALLOWS ADJUSTMENT OF THE HOT GAS REHEAT PI CONTROL LOOP.**

*This screen only appears if hot gas reheat was provided with the unit.*

The controller utilizes a PI loop control for reheat. This allows for less sporadic changes in supply air temperature, resulting in a smooth reaction to changing conditions. To speed up reaction time, decrease the integration time. For slower reaction time, increase the integration time. When making adjustments, make them in small increments and test the system to determine if the new setting is adequate prior to further adjustment. The band is the range that the integration will occur between.

### **THIS SCREEN ALLOWS ADJUSTMENT OF THE MINIMUM ON/OFF TIMES FOR THE HOT GAS REHEAT COIL.**

*This screen appears if ON/OFF hot gas reheat was provided with the unit.*

This is the minimum on/off time operation for the hot gas reheat coil. The minimum run time prevents short cycling of the coil, allowing for better oil distribution through the DX system. CONSULT THE FACTORY BEFORE CHANGING MINIMUM ON/OFF HOT GAS REHEAT TIMES.



### Hot Gas Flush Setup

Cycle: 30minutes  
Duration: 1minutes

### Mod Hot Gas Setup

Minimum ON: 4.0vdc  
Maximum ON: 10.0vdc

### Supply Reset Control

Integration: 1200s  
Band: 10°F

### Heat/Cool Delay

Time delay between heating,  
cooling &/or economizer  
modes. Delay: 180s

### Unoccupied Mode Setup

Type: CycleSupplyFan  
Source: Input ID6

### Damper Setup

Allow the dampers to open  
for: 10 seconds before  
starting the fans.

### Fan/Airflow Proving

Alarm delay: 30s  
(inputs ID1 & ID5)

---

#### ***THIS SCREEN ALLOWS ADJUSTMENT OF THE HOT GAS FLUSH SYSTEM.***

---

*This screen appears if hot gas reheat with flush was provided (except heat pump).*

The hot gas flush cycle is designed to provide a momentary flush of the hot gas reheat system. This prevents the build up of oil in the reheat coil. The flush sequence starts by fully opening the reheat valve for a period of Duration (Factory Default = 1 minute). Once the flush duration is complete, the valve resumes modulation for a period of Cycle (Factory Default = 30 minutes).

---

#### ***THIS SCREEN ALLOWS ADJUSTMENT OF THE HOT GAS REHEAT BYPASS DAMPER.***

---

*This screen appears if modulating hot gas reheat was provided.*

---

#### ***THIS SCREEN ALLOWS ADJUSTMENT OF THE SUPPLY RESET PI CONTROL LOOP, FOR ROOM TEMP CONTROL.***

---

*This screen only appears if a Room Temp Sensor is wired to controller terminals B4 and BC4.*

The controller utilizes a PI loop control for supply reset based on room temp. This allows for less sporadic changes in supply air temperature, resulting in a smooth reaction to changing conditions. To speed up reaction time, decrease the integration time. For slower reaction time, increase the integration time. When making adjustments, make them in small increments and test the system to determine if the new setting is adequate prior to further adjustment. The band is the range that the integration will occur between.

---

#### ***THIS SCREEN ALLOWS ADJUSTMENT OF THE DELAY BETWEEN HEAT AND COOL MODES.***

---

This time delay prevents short cycling between heating, cooling and/or economizer modes.

---

#### ***THIS SCREEN DISPLAYS WHAT THE UNIT WILL DO IN UNOCCUPIED MODE.***

---

Setting the Type to CycleSupplyFan will engage the unit to maintain space temperature. However, a room temperature sensor must be wired between controller terminals B4 and BC4. If desired, the Source offers three options to control occupancy. The factory default is terminal ID6 on the controller.

**Input ID6:** Typically used with a remote time clock, motion sensor or switch (default).

**BMS:** BMS control (see Points List). BMS can be overridden with ID6.

**Time Clock:** Internal time clock (Scheduler). See Clock/Scheduler menu for more information. The Scheduler can be overridden with digital input ID6.

Without the room temperature sensor, the Type will be Unit Off, forcing the unit off during unoccupied mode.

---

#### ***THIS SCREEN ALLOWS ADJUSTMENT OF THE FAN START DELAY.***

---

This timer allows the damper time to open before the fan start sequence begins. This prevents the fans from having to overcome higher static pressure when the damper(s) are opening. (Factory Default = 10 seconds)

---

#### ***THIS SCREEN ALLOWS ADJUSTMENT OF THE FAN AIRFLOW PROVING SWITCH TIME DELAY.***

---

Since the unit is only part of a complete system, the airflow(s) may momentarily change (ie. If a downstream damper closes). This delay is intended to prevent false loss of airflow alarms. (Factory Default = 30 seconds)



Fan Delay	
Time delay between starting of supply & exhaust fans. Fan delay:	15s

Wheel Rotation Sensor	
Alarm delay: (input ID3)	30s

Temperature Scale	
Select:	Fahrenheit
Display Buzzer	
Select:	Disable

## H. Manufacturer

### d. Initialization

Factory Settings	
	
Save?	No
Restore?	No

New Password	
	
Insert new manufacturer password (PW2):	0000

Initialization	
DEFAULT INSTALLATION Erase user settings and install global default values:	No

**THIS SCREEN ALLOWS ADJUSTMENT OF THE TIME DELAY BEFORE THE EXHAUST FAN WHEN THE SUPPLY FAN STARTS.**

*This screen only appears if an energy wheel was provided with the unit.*

The delay between the starting of supply and exhaust fans reduces the startup amp draw of the unit. The exhaust fan engages first, allowing the energy wheel to see space temperature conditions prior to the supply fan engaging. This allows the wheel to provide maximum preconditioning of the outdoor air. This also minimizes the potential of extreme outdoor air temperatures being supplied to the space, prior to the cooling or heating engaging.

**THIS SCREEN ALLOWS ADJUSTMENT OF THE TIME DELAY FOR WHEEL ROTATION ALARM.**

*This screen only appears if an energy wheel was provided with the unit.*

Similar to the Fan/Airflow Proving Switch alarm, the energy wheel rotation alarm delay allows time to elapse prior to the controller showing an alarm. The delay prevents a false alarm from occurring if the sensor does not sense the wheel rotation for the allotted time.

**THIS SCREEN ALLOWS THE USER TO ADJUST WHAT TEMPERATURE UNITS THE CONTROLLER SHOULD DISPLAY AND WHETHER THE DISPLAY BUZZER SHOULD BE ENABLED OR DISABLED.**

The temperature unit of measurement can either be Fahrenheit or Celsius. If using Celsius, the user will need to manually convert the factory default parameters in the **Factory Settings** menu.

The display buzzer is only applicable when a remote interface panel is attached to the controller. If an alarm were to occur, the remote display panel would begin buzzing loudly (if the buzzer was enabled) and would show the alarm status.

The Initialization Menu allows the user to save and restore the controllers default parameters. The controller can be restored with either the Manufacturer's default parameters from shipment, or an unconfigured factory default.

**THIS SCREEN ALLOWS THE USER TO SAVE AND RESTORE THE FACTORY DEFAULT PARAMETERS STORED IN MEMORY.**

The Factory Settings include the Factory default parameters and the unit setup code. If the user would like to restore to these parameters, move the cursor to the Restore position and change to YES.

**THIS SCREEN ALLOWS THE USER TO CHANGE THE MANUFACTURER PASSWORD (PW2)**

**THIS SCREEN ALLOWS THE USER TO RESTORE BACK TO THE ORIGINAL FACTORY DEFAULT PARAMETERS.**

Restoring to the original default parameters will result in a non-customized controller. The user should not restore to these settings unless instructed by the factory.

## Points List

Modbus-RTU/TCP/IP Network Address: 1		BACnet IP/Ethernet BACnet MSTP Device Instance: 77000(default)			LonWorks FTT-10A			Type	Read (Unit to BMS signal) Write (BMS to Unit signal)	Description
Address	Address	Name	Units	NV_Index	Name NV	Type NV				
40002	1	A001	°F	12	nvoOutsideTemp	105	Analog	R	Outdoor Air Temp (###.°F)	
40003	2	A002	°F	13	nvoSupplyAirTemp	105	Analog	R	Supply Air Temp (###.°F)	
40004	3	A003	°F	14	nvoColdCoilDisch	105	Analog	R	Cold Coil Temp (###.°F)	
40005	4	A004	°F	15	nvoRoomTemp	105	Analog	R	Room AirTemp (if installed) (###.°F)	
40012	11	A011	°F	16 / 3	nv(o/i)TempSetPt	105	Analog	R/W	Temperature SetPt (read/write) (###.°F) (See Controller IOM)	
40013	12	A012	°F	17	nvoActiveTempSP	105	Analog	R	Active Temperature Set Point (###.°F)	
40210	1001	I001	no-units	23	nvoStatus	8	Integer	R	Note 1 (See below)	
40211	1002	I002	percent	24	nvoHeating	81	Integer	R	Heater output (0-100%)	
40212	1003	I003	percent	25	nvoCooling	81	Integer	R	Cooling output (0-100%)	
40213	1004	I004	percent	26	nvoWheel	81	Integer	R	Energy recovery wheel speed	
40214	1005	I005	percent	27	nvoHotGasReheat	81	Integer	R	Hot Gas reheat output (0-100%)	
pCOe Analog Variables										
40022	21	A021	°F or Percent	18	nvoAux_AI1	9	Analog	R	pCOe Analog Input Probe Value 1	
40023	22	A022	°F or Percent	19	nvoAux_AI2	9	Analog	R	pCOe Analog Input Probe Value 2	
40024	23	A023	°F or Percent	20	nvoAux_AI3	9	Analog	R	pCOe Analog Input Probe Value 3	
40025	24	A024	°F or Percent	21	nvoAux_AI4	9	Analog	R	pCOe Analog Input Probe Value 4	
40026	25	A025	percent	22 / 4	nv(o/i)Aux_A01	81	Analog	R/W	pCOe Auxillary Analog Out (0-10V)	
			Inactive_Text	Active_Text						
10002	1	D001	Off	On	28	nvoOnOffStat	95	Digital	R	Unit ON/OFF status
10003	2	D002	Off	On	29	nvoSupplyFan	95	Digital	R	Supply fan status
10004	3	D003	Off	On	30	nvoExhaustFan	95	Digital	R	Exhaust fan status
10005	4	D004	Unoccupied	Occupied	31	nvoOccupancyStat	95	Digital	R	Occupancy Status (0=Unoccupied, 1=occupied)
10006	5	D005	Off	On	32	nvoCompressor1	95	Digital	R	Compressor #1 status
10007	6	D006	Off	On	33	nvoCompressor2	95	Digital	R	Compressor #2 status
10008	7	D007	Off	On	34	nvoDefrostMode	95	Digital	R	Defrost mode status
10011	10	D010	Stop	Start	35 / 5	nv(o/i)StartStop	95	Digital	R/W	Unit start/stop command
10012	11	D011	Don't Reset	Reset Alarms	36 / 6	nv(o/i)ResetAlarms	95	Digital	R/W	Reset alarms command
10013	12	D012	Occupied	Unoccupied	37 / 7	nv(o/i)OccUnocc	95	Digital	R/W	Occupied/unoccupied command (0=occupied, 1=unoccupied)
10021	20	D020	Off	Alarm	38	nvoGlobalAlarm	95	Digital	R	Global alarm indication (active when there is at least one alarm)
					39	nvoAlarms	83			Alarms
10022	21	D021	Off	Alarm	bit0	nvoSupplyFanAlm		Digital	R	Supply airflow proving alarm
10023	22	D022	Off	Alarm	bit1	nvoWhlPressurAlm		Digital	R	High wheel pressure (high airflow or dirty wheel)
10024	23	D023	Off	Alarm	bit2	nvoWhlRotateAlm		Digital	R	Wheel rotation alarm
10025	24	D024	Off	Alarm	bit3	nvoExhaustFanAlm		Digital	R	Exhaust airflow proving alarm
10026	25	D025	Off	Alarm	bit4	nvoFilterAlm		Digital	R	Dirty filter alarm
10027	26	D026	Off	Alarm	bit5	nvoCompTripAlm		Digital	R	Compressor trip alarm
10028	27	D027	Off	Alarm	bit6	nvoSupplyTempAlm		Digital	R	Supply air temperature low limit alarm
10029	28	D028	Off	Alarm	bit7	nvoB1Alm		Digital	R	Sensor#1 out of range (outside air temperature)
10030	29	D029	Off	Alarm	bit8	nvoB2Alm		Digital	R	Sensor#2 out of range (supply air temperature)
10031	30	D030	Off	Alarm	bit9	nvoB3Alm		Digital	R	Sensor#3 out of range (cold coil leaving air temperature)
10032	31	D031	Off	Alarm	bit10	nvoB4Alm		Digital	R	Sensor#4 out of range (room temperature)
pCOe Digital Variables										
					40	nvoAuxiliary_DI	83			pCOe Digital Inputs
10052	51	D051	Off	On	bit0	nvoAux_DI1		Digital	R	pCOe Auxillary Digital Input1
10053	52	D052	Off	On	bit1	nvoAux_DI2		Digital	R	pCOe Auxillary Digital Input2
10054	53	D053	Off	On	bit2	nvoAux_DI3		Digital	R	pCOe Auxillary Digital Input3
10055	54	D054	Off	On	bit3	nvoAux_DI4		Digital	R	pCOe Auxillary Digital Input4
10056	55	D055	Off	On	41 / 8	nvoAux_D01	95	Digital	R/W	pCOe Auxillary Digital Output1
10057	56	D056	Off	On	42 / 9	nvoAux_D02	95	Digital	R/W	pCOe Auxillary Digital Output2
10058	57	D057	Off	On	43 / 10	nvoAux_D03	95	Digital	R/W	pCOe Auxillary Digital Output3
10059	58	D058	Off	On	44 / 11	nvoAux_D04	95	Digital	R/W	pCOe Auxillary Digital Output4

### Unit Status Index

0 System Off	5 System On	10 System On - Dehumidifying	15 Manual Override
1 Initial Delay	6 Defrost Mode Active	11 System On - Dehumidifying & Reheat	16 Remote Off
2 Opening Dampers	7 System On - Economizer	12 Unoccupied - Unit Off	17 Alarm
3 Exhaust Fan Starting	8 System On - Heating	13 Unoccupied - Heating	
4 Supply Fan Starting	9 System On - Cooling	14 Unoccupied - Cooling	



## Auxiliary I/O (pCOe)



The pCOe is an Auxiliary I/O module that can be used to monitor additional statuses within the unit. The pCOe allows the user to view:

- 4 Digital Inputs
- 4 Digital Outputs
- 4 Analog Inputs
- 1 Analog Output

The inputs can be monitored either via the controller display or Building Management System. See Points List for detailed point information.

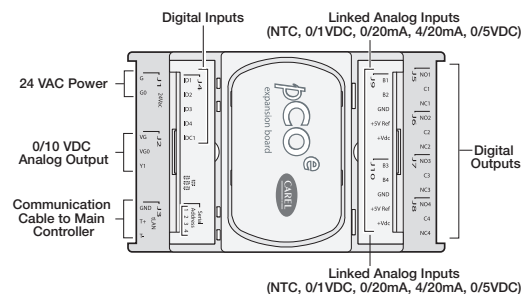

## Setup

In order for the main controller to read the Auxiliary I/O, several parameters must be set in the menu screens. (If you have a pCOe installed from the factory, the controller is most likely already set up for communication with the main controller.)

### Unit Expansion I/O

Enable Expansion	Yes
------------------	-----

**Enable Expansion I/O** - Go to **Manufacturer > Configuration**. You will have to enter the Manufacturer password (Default = 1000). Go to the Unit Expansion I/O screen, and make sure Enable Expansion = Yes.

### pCOe I/O Config

pCOe number:	1
Analog input type	
Ch 1&2 :	4.. 20 mA
Ch 3&4 :	Carel NTC

**Customize Analog Inputs** - The analog inputs are grouped in pairs according to their input types (Channels B1, B2 and Channels B3, B4). To select the input type, go to **Manufacturer > I/O Configuration**. You will have to enter the Manufacturer password (Default = 1000). At the very end of the menu are the I/O Config screens for the pCOe analog inputs.

### pCOe I/O Config

pCOe number:	1
Analog input limits	
Ch 1 Min:	0.0
Ch 1 Max:	10.0
Ch 2 Min:	0.0
Ch 2 Max:	10.0

The pCOe analog inputs are set up as Carel NTC temperature probes default from the factory. The analog inputs can be also be set for the following input types: 0/1VDC, 0/20mA, 4/20mA or 0/5VDC.

If selected as anything other than Carel NTC, the user has the capability to scale the input to match the probe range. An example screen is shown on the left.

### pCOe Digital Inputs

pCOe number:	1
Channel ID1:	Open
Channel ID2:	Open
Channel ID3:	Open
Channel ID4:	Open

**View Input Values** - To view input values, go to **Input/Output**. At the very end of the menu are the status screens of the pCOe inputs and outputs. Similarly, the pCOe I/O values can be viewed on the BMS. See Points List for more details.

### pCOe Analog Channels













pCOe number:	1
Input B1:	0.0
Input B2:	0.0
Input B3:	70.0°F
Input B4:	70.0°F
Output Y1:	0.0vdc

### pCOe Digital Outputs

pCOe number:	1
Output NO1:	OFF
Output NO2:	OFF
Output NO3:	OFF
Output NO4:	OFF



## Troubleshooting

Display is hard to read.	<p>Unit Controller Display: Hold  ESC and  ENTER at the same time, while pressing  DOWN or  UP to adjust display contrast.</p> <p>Remote Display: Hold  ALARM,  PRG, and  ESC at the same time, while pressing  DOWN or  UP to adjust display contrast.</p>
Remote display panel displays “NO LINK” or is blank.	Hold  DOWN,  UP and  ENTER for 4 seconds. Set the display address to 32. The display requires a standard 24 AWG six conductor phone cable connected to the unit controller.
Red alarm button is flashing.	Press the  ALARM button to review and clear unit alarms. Enter the DATA LOGGER menu to view previous alarms.
Controller resets itself or is not on.	Check the supply voltage to the controller at terminals G-G0. The board requires 24VAC. Check the 24VAC transformer in the unit control center.
Menus are locked with a password.	The factory default Manufacturer Password = 1000. The factory default Service Password = 1000.
Temperature sensor failure.	Check the analog input terminal block (labeled terminals B1, B2, B3, etc) for loose wires. Disconnect temperature sensors to check sensor resistance.

## NTC Temperature Sensor Chart

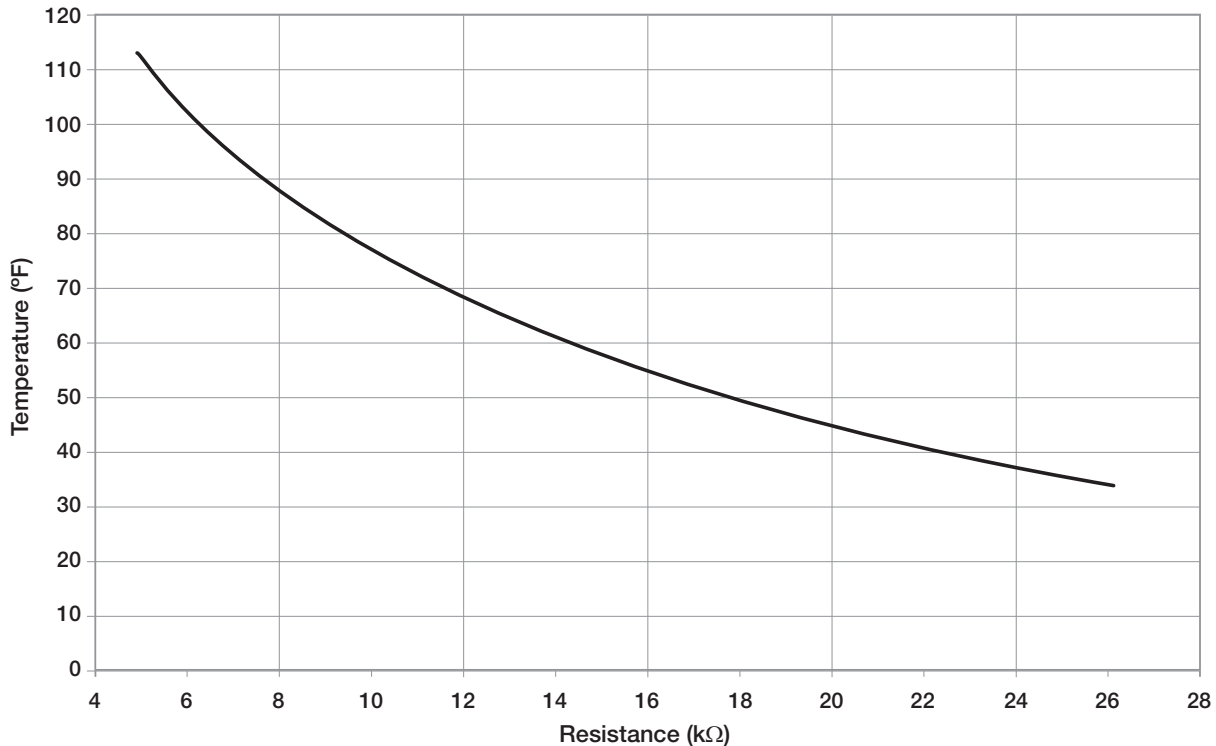

## BACnet MSTP Quick Start

The card is loaded with the following default BACnet MSTP parameters.

Parameter	Factory	Minimum	Maximum
Device Instance	77000	0	4194303
Station Address	0	0	127
Max Master	127	0	127
Max Info Frames	20	0	255
Baudrate	38400	9600-19200-38400-76800	

### G. Service

#### c. BMS Config

#### BMS Configuration

Protocol: BACnet MSTP  
BACnet Plugin? YES

#### MSTP SETUP

Instance: 77000  
Baudrate 38400  
MAC Addr: 0  
MaxMasters: 127  
MaxInfoFrames: 20

#### BACnet Read/Write

Function: Read  
Update? Yes  
\*Cycle unit power to confirm write command.

To view the current parameters, go the **BMS Config** menu within the controller by pressing the **Prog** key.

To access the **BMS Config** sub-menu, enter the service-password (Default=1000).

**Protocol must be BACnet MSTP and BACnet Plugin must be YES.**

Press the **Down** button arrow to view next screen.

Current BACnet MSTP parameters should be displayed. If values appear to be zero, follow the procedure below.

**To read current settings:**

1. Power on controller and allow several minutes to initialize.

2. Go to **BMS Config** menu and view BACnet Read/Write screen.

3. Change *Function* to *Read* and *Update?* to *YES*.

Current BACnet MSTP parameters should now be displayed in the BACnet MSTP SETUP screen. If all values appear to be zeros, consult the factory. (Make sure you have allowed several minutes for the controller to initialize). \*Values may appear to be zero prior to setting the Function to READ.

**To change BACnet MSTP parameters:**

1. Power on the controller and allow several minutes to initialize.

2. Go to **BMS Config** menu and view MSTP SETUP screen.

3. Move cursor to desired parameter by pressing the **Down** **Up** buttons. Press **Enter** to select the parameter to change. Press the **Down** **Up** buttons to adjust the parameter. Press **Enter** to save adjusted value.

4. Once desired parameters have been entered, go to BACnet Read/Write screen. Change *Function* to *Write* and *Update?* to *YES*.

5. Reboot the controller by cycling power to the unit. Allow several minutes for the controller to initialize.

6. View MSTP parameters. If changed values did not save, contact the factory.

The communication card is located in the **Serial Card** port on the face of the controller. The card includes two sets of LED lights for communication troubleshooting.

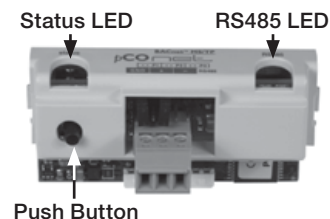

**Status LED:** Indicates the status of communication between the card and controller.

- Quick green-off-green if communication with controller is ok.
- Slow red-off-red if communication is not established.

**RS485 LED:** Indicates the status of communication with the BACnet MSTP network. Wait for 40 seconds to determine status of communication.

- Green with occasional red, communication is OK.
- Green and red both on, communications is not established.

### Communication Troubleshooting

See Carel Data sheet for more info.

If attempting to communicate with the controller over BACnet MSTP, refer to the card LEDs for system information.

**Status LED slow red blink**

- Confirm card is firmly plugged in.
- Confirm BMS Protocol is set to BACnet MSTP.

**RS485 LED green and red both on**

- Confirm system and card baudrate are the same.
- Confirm card Max Master is equal to or greater than the Station (MAC) Address of the Master with the highest address.

### Recalling Factory Parameters

Follow this procedure to revert to factory parameters for one power cycle. When restarted, the card will resume using the previous user parameters.

1. With controller off, hold the push button located on the BACnet MSTP card, while powering the controller back on.
2. Continue to hold the button, while watching the **Status LEDs**. Wait for the Status LEDs to blink red slowly, and release before the third slow flash.
3. Wait for about one minute for the factory parameters to be loaded.



**\*The BACnet IP/Eth card is configured for DHCP from the factory.**

To view the current parameters, go the **BMS Config** menu within the controller by pressing the **Prog** key.

**G. Service**  
c. BMS Config

BMS Configuration	
Protocol:	BACnet IP/Eth
BACnet Plugin?	YES

TCP/IP SETUP	
Instance:	77000
IP set by:	DHCP
IP:	128.1.104.134
Subnet:	255.255.000.000
Gateway:	128.1.0.12

TCP/IP Setup	
DNS 1:	193.168.001.001
DNS 2:	193.168.001.001
Type:	IP

BACnet Read/Write	
Function:	Read
Update?	Yes
*Cycle unit power to confirm write command.	

be displayed in the BACnet TCP/IP SETUP screen. If all values appear to be zeros, consult the factory. (Make sure you have allowed several minutes for the controller to initialize). *\*Values may appear to be zero prior to setting the Function to READ.*

To change BACnet TCP/IP parameters:

1. Power on the controller and allow several minutes to initialize.
2. Go to **BMS Config** menu and view TCP/IP SETUP screen.
3. Move cursor to desired parameter by pressing the **↓** **↑** buttons. Press **↻** to select the parameter to change. Press the **↓** **↑** buttons to adjust the parameter. Press **↻** to save adjusted value.
4. Once desired parameters have been entered, go to BACnet Read/Write screen. Change *Function* to *Write* and *Update?* to *YES*.
5. Reboot the controller by cycling power to the unit. Allow several minutes for the controller to initialize.

To access the **BMS Config** sub-menu, enter the service password (Default=1000).

Protocol must be **BACnet IP/Eth** and **BACnet Plugin** must be **YES**.

Press **↓** arrow button to view next screen.

Current BACnet IP parameters should be displayed. If values appear to be zero, follow the procedure below.

To read current parameters:

1. Power on controller and allow several minutes to initialize.
2. Go to **BMS Config** menu and view BACnet Read/Write screen.
3. Change *Function* to *Read* and *Update?* to *YES*.

Current BACnet IP parameters should now

6. View TCP/IP parameters. If changed values did not save, contact the factory.

The communication card is located in the **Serial Card** port on the face of the controller. The card includes two sets of LED lights for communication troubleshooting.

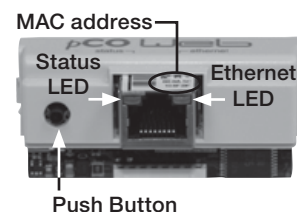

**Status LED:** Indicates the status of communication between the card and controller.

- Quick green-off-green if communication with controller is ok.
- Slow red-off-red if communication is not established.

**Ethernet LED:** Indicates the status of communication with the network. Wait for 40 seconds to determine status of communication.

- Flashing green, communication is OK.
- Steady red, communications is not established.

### Communication Troubleshooting

See Carel Data sheet for more info.

If attempting to communicate with the controller over BACnet IP/Eth, refer to the card LEDs for system information.

**Status LED slow red blink**

- Confirm card is firmly plugged in.
- Confirm BMS Protocol is set to BACnet IP/Eth.

**Ethernet LED red on**

- Confirm card is connected to the network.

### Recalling Factory Parameters

Follow this procedure to revert to factory parameters for one power cycle. When restarted, the card will resume using the previous user parameters.

Factory Default IP address: 172.016.000.001

1. With controller off, hold the push button located on the BACnet IP/Eth card, while powering the controller back on.
2. Continue to hold the button, while watching the **Status LED**. Wait for the Status LED to blink red slowly, and release before the third slow flash.
3. Wait for about one minute for the factory parameters to be loaded.
4. Follow the procedure to read the current parameters to confirm factory defaults have been loaded.



## Maintenance Log

Date \_\_\_\_\_ Time \_\_\_\_\_ AM/PM

Notes: \_\_\_\_\_

---

---

---

---

Date \_\_\_\_\_ Time \_\_\_\_\_ AM/PM

Notes: \_\_\_\_\_

---

---

---

---

Date \_\_\_\_\_ Time \_\_\_\_\_ AM/PM

Notes: \_\_\_\_\_

---

---

---

---

Date \_\_\_\_\_ Time \_\_\_\_\_ AM/PM

Notes: \_\_\_\_\_

---

---

---

---

Date \_\_\_\_\_ Time \_\_\_\_\_ AM/PM

Notes: \_\_\_\_\_

---

---

---

---

Date \_\_\_\_\_ Time \_\_\_\_\_ AM/PM

Notes: \_\_\_\_\_

---

---

---

---

Date \_\_\_\_\_ Time \_\_\_\_\_ AM/PM

Notes: \_\_\_\_\_

---

---

---

---

Date \_\_\_\_\_ Time \_\_\_\_\_ AM/PM

Notes: \_\_\_\_\_

---

---

---

---

Date \_\_\_\_\_ Time \_\_\_\_\_ AM/PM

Notes: \_\_\_\_\_

---

---

---

---

Date \_\_\_\_\_ Time \_\_\_\_\_ AM/PM

Notes: \_\_\_\_\_

---

---

---

---

Date \_\_\_\_\_ Time \_\_\_\_\_ AM/PM

Notes: \_\_\_\_\_

---

---

---

---

Date \_\_\_\_\_ Time \_\_\_\_\_ AM/PM

Notes: \_\_\_\_\_

---

---

---

---



## Warranty

---

Accurex warrants this equipment to be free from defects in material and workmanship for a period of one year from the shipment date. Any units or parts which prove to be defective during the warranty period will be replaced at our option when returned to our factory, transportation prepaid. Motors are warranted by the motor manufacturer for a period of one year. Should motors furnished by Accurex prove defective during this period, they should be returned to the nearest authorized motor service station. Accurex will not be responsible for any removal or installation costs.

*As a result of our commitment to continuous improvement, Accurex reserves the right to change specifications without notice.*



P.O. Box 410 Schofield, WI 54476  
Phone: 800.333.1400 Fax: 715.241.6191  
[www.accurex-systems.com](http://www.accurex-systems.com)