

## Installation, Operation and Maintenance Manual

Please read and save these instructions for future reference. Read carefully before attempting to assemble, install, operate or maintain the product described. Protect yourself and others by observing all safety information. Failure to comply with instructions could result in personal injury and/or property damage!



### Product Specification

#### Digital Temperature Interlock

International Mechanical Code (IMC) 2006 section 507.2.1.1 Compliant Electrical Package

Provide Accurex temperature interlock electrical package as shown on plans and in accordance with the following specification:

The temperature interlock(s) consists of a temperature controller, resistive temperature detector (RTD), junction box, fire proof/leak proof threaded fitting (Evergreen Quik-Seal<sup>®</sup> and/or Evergreen Compression Seal), and shall be a self-contained unit or as part of another pre-engineered electrical control package.

The temperature interlock package shall close a relay powering the fans when the sensor detects the temperature set point. The interlock shall hold the circuit closed upon fan switch being turned off until the temperature sensor detects a temperature below the set point plus hysteresis. Once the temperature is below the set point plus hysteresis, the fans shall shut down.

The temperature interlock package shall be constructed by Accurex in accordance with International Mechanical Code. The manufacturer shall provide, upon request, the necessary data that confirms compliance with the code listed above.

Due to continuous research, Accurex reserves the right to change specifications without notice.

### General Description

#### Description

The temperature interlock is designed to automatically start kitchen hood exhaust fans and keep them running while heat is being generated from the cooking appliances. Hood systems should always be manually started before equipment is turned on. If the fans are forgotten to be turned on, the interlock will turn the fans on once heat is detected. The interlock consists of a temperature controller, resistive temperature detector (RTD), junction box, Evergreen Compression Seal threaded fitting, and is contained in a stand alone box or can be added to a pre-engineered fan control center.

#### Purpose

To meet IMC 2006 section 507.2.1.1, interlock between exhaust fans and cooking equipment. This system will utilize a temperature sensor in the exhaust duct collar or in capture area of hood to detect heat generated from cooking operations and automatically activate the exhaust fans if not already turned on. Field wiring may be required depending on location of components.

#### Product Application

The temperature interlock is designed to be used with Type I and Type II hoods. It is not to be used in conjunction with exhaust fire dampers. Accurex recommends using one interlock per hood system (activates all fans linked to system simultaneously).

#### Performance Goals

Automatically energize the exhaust fans when cooking equipment generates heat. Basic controls will be provided with a temperature sensor and will consist of an 8 x 8 electrical box with controls and a labeled terminal strip to hook-up incoming power and fan starters. A temperature controller is used to keep the exhaust fans running when the temperature controller initially closes to prevent the fan from cycling on and off at startup and shut down. Fans will shut down automatically once the temperature has gone below the set point plus hysteresis. The hysteresis can be adjusted based on jobsite requirements.

## Table of Contents

---

Product Specification . . . . .	1
General Description . . . . .	1
Receiving and Handling . . . . .	2
Installation	
Hood Mounting . . . . .	3
Duct Collar Mounting . . . . .	3
Electrical Connections	
Temperature Sensor . . . . .	4
Breaker Panel to Control Box or Fan Control Center . . . . .	4
Circuit Connections . . . . .	4
Calibration . . . . .	4
Control Circuit Diagrams . . . . .	5-6
Testing . . . . .	7
Operation . . . . .	7
Troubleshooting . . . . .	7
Maintenance . . . . .	7
Frequently Asked Questions . . . . .	8
Replacement Parts . . . . .	8
Codes and Standards Compliance . . . . .	8
Warranty . . . . .	8

## Receiving and Handling

---

Upon receiving the equipment, check for both obvious and hidden damage. Check to be sure that all parts of the shipment, including accessories, are accounted for.

### Storage

If a temperature interlock must be stored prior to installation, it must be protected from dirt and moisture. Indoor storage is recommended. For outdoor storage, cover the control package with a tarp to keep it clean, dry, and protected from UV (ultraviolet) radiation damage.

Improper storage which results in damage to the unit will void the warranty.



# Installation

## Control Box Mounting

Locate an area with enough space to mount the control box and fasten to the wall.

### NOTE

Control box may be factory mounted. If so, continue to the next section.

## Resistive Temperature Detector(s) (RTD) Mounting

### NOTE

Resistive temperature detector(s) may be factory installed. If so, continue to the next section.

1. Locate flat area(s) at the top interior of the hood in front of the filters, towards the front of the hood.

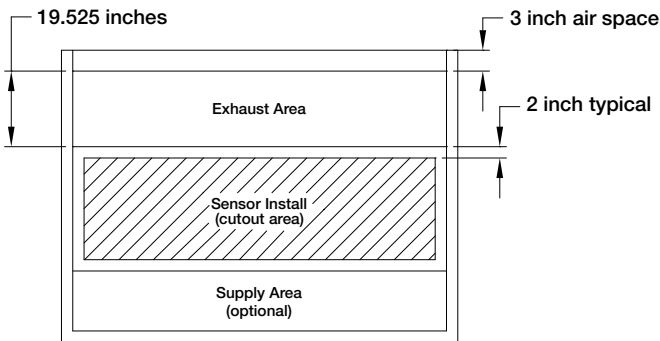

Top View of Exhaust Hood

2. Cut a 3/4 to 7/8-inch diameter hole in the flat spot of the capture tank. Make sure the resistive temperature detector(s) will not interfere with fire system nozzles and is not within 12 inches of light fixtures.
3. Place the J-box plate inside of the octagon extension ring and place over the hole.
4. Disassemble the compression seal and place through hole and J-box plate as shown. Tighten the nut inside the octagon extension ring.

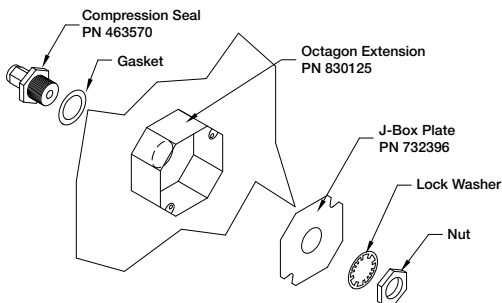

5. Place the resistive temperature detector through the compression seal and tighten the compression fitting.

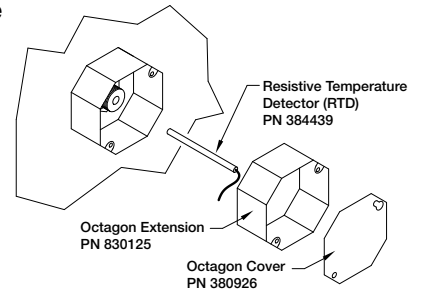

6. Install the cover for the octagon box.

## Duct Collar Mounting

1. Locate the exhaust duct on top of the hood. A 3/4 to 7/8-inch (19.0 to 22.2 mm) diameter hole must be cut into the duct 2 inches (50.8 mm) above the hood top. Center the hole along the side of the duct. Make sure that the resistive temperature detector will not interfere with any fire system nozzles, or other items installed in the exhaust duct. If an exhaust fire damper is present the hood exhaust collar, it must be removed prior to temperature sensor installation.

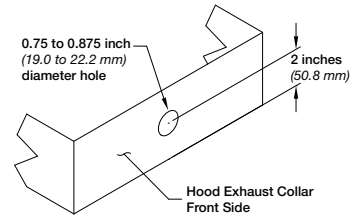

2. Place the J-box plate inside of the octagon extension ring and place over the hole in the exhaust collar.
3. Disassemble the compression seal and place through hole in duct collar and J-box plate as shown. Tighten the nut inside the octagon extension ring.

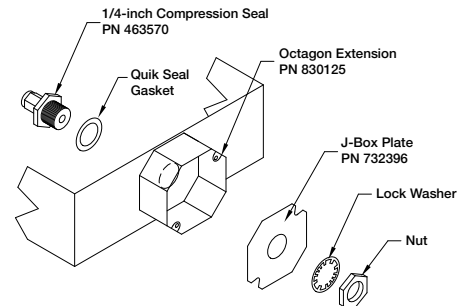

4. Place the resistive temperature detector through the compression seal and tighten the compression fitting.

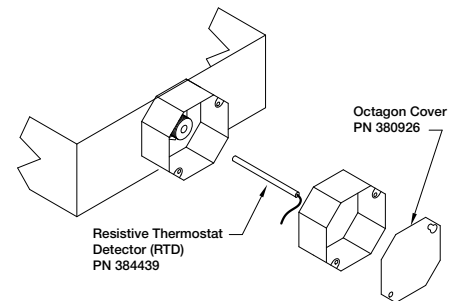

5. Install the cover for the octagon box.

### NOTE

All field installation and wiring of electrical equipment must be done to meet NEC and local codes.

# Electrical Connections

## Electrical Connections

1. Run two 18 awg thermostat wire from each temperature sensor to the appropriate electrical circuit connections. (See Step 3 for connection options).
2. In junction box, connect leads on RTD to the 18 awg conductors using appropriate size wire nuts.
  - Wires are interchangeable with one another.
3. Choose the final connection based on:
  - Terminals T3, T4, T5, T6, T7, T8 (if applicable) in fan control center (XFCC).
  - Terminals 9, 10, 11, 12, 13, 14, 15, 16, 17, 18 (if applicable) in control box on top of hood/utility cabinet.

### CAUTION

Do not connect temperature sensor in series with fan power. This will result in damage to the temperature sensor and will require replacement.

## Breaker Panel to Control Box or Fan Control Center

1. Connect a Single Pole Single Throw (SPST) switch to one of the following based on application:
  - Terminals 3 & 4 in the control box.
  - Terminals S1 & S1H in the fan control center.

## Circuit Connections

1. Standard Interlock Control
  - 120V, 10 or 15 amp circuit to terminals 1 & 2
  - Control voltage for fan starter activation
    - 120V, 24V or other control circuit  
(drawing on page 5)
  - Control circuit power to terminal 7
  - Terminal 8 to fan starter coils
  - Terminals 7 & 8 to fan starter coils
2. Fan Control Center Integration (XFCC)
  - Power to H1 & N1 in fan control center
  - No additional control circuits are required fan starters are factory wired

## Calibration

The temperature controller is preset by the factory to turn the fans on at 95°F. This is controlled by the set point on the temperature controller. The temperature set point may have to be adjusted slightly depending on both ambient and cooking conditions. The adjustment is made through the buttons on the temperature controller. To adjust, follow these instructions:

1. Press the SET button to see the set point.
2. Press the UP/DOWN arrow button to change the set point.
3. Press the SET button to view the current temperature.
4. Check system operation before making additional adjustments.



# Control Circuit Diagram (Standard Control)

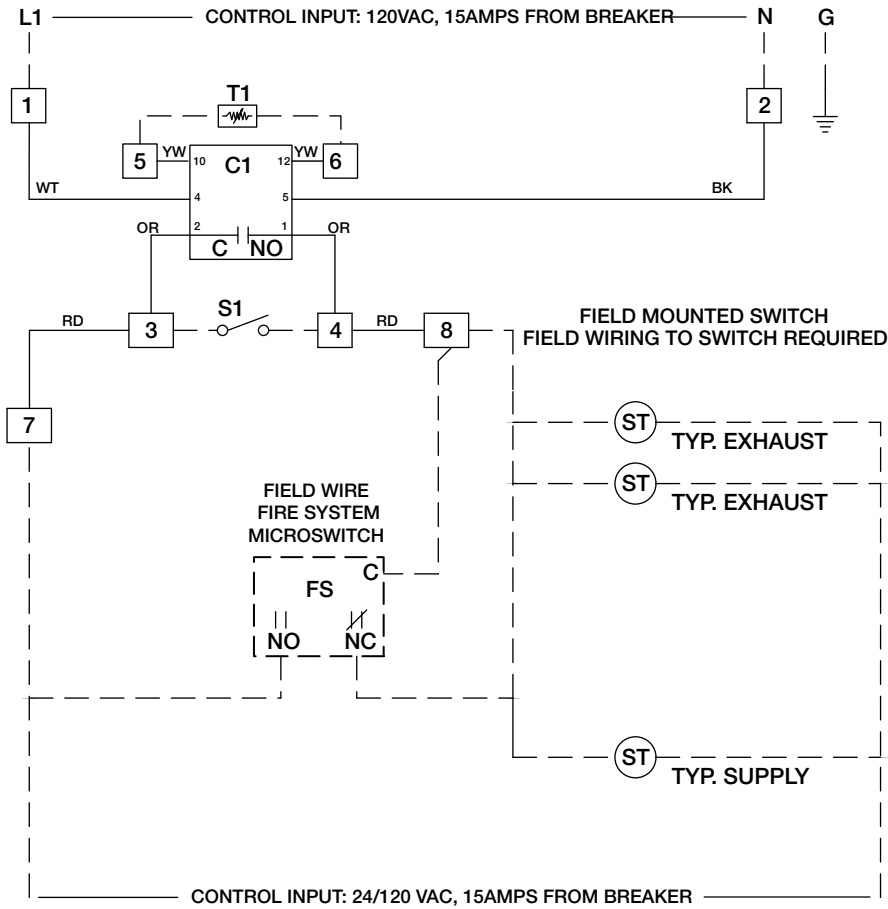

UL LISTED		UNDER SUBJECT 891 FILE #E200616
<b>LABEL DESCRIPTION</b>	—————	FACTORY WIRING
EF Exhaust Fan	-----	FIELD WIRING
SF Supply Fan		
ST Starter		ALL WIRING 90°C 14 GA. UNLESS SPECIFIED
OL Overload		
G Ground		
S1 Switch		<b>WIRE COLOR</b>
FS Fire Switch		BK - black
STB Shunt Trip Breaker		BL - blue
N Neutral		BR - brown
T1-T6 RTD Temperature Sensor		OR - orange
FS Fire System Microswitch		PR - purple
C1-C6 Controller, Dwyer 40-T		RD - red
		YW - yellow
		WT - white
<b>FIELD WIRING:</b> use minimum 60° Copper Wire		

## WIRING FOR ADDITIONAL SENSORS (OPTIONAL)

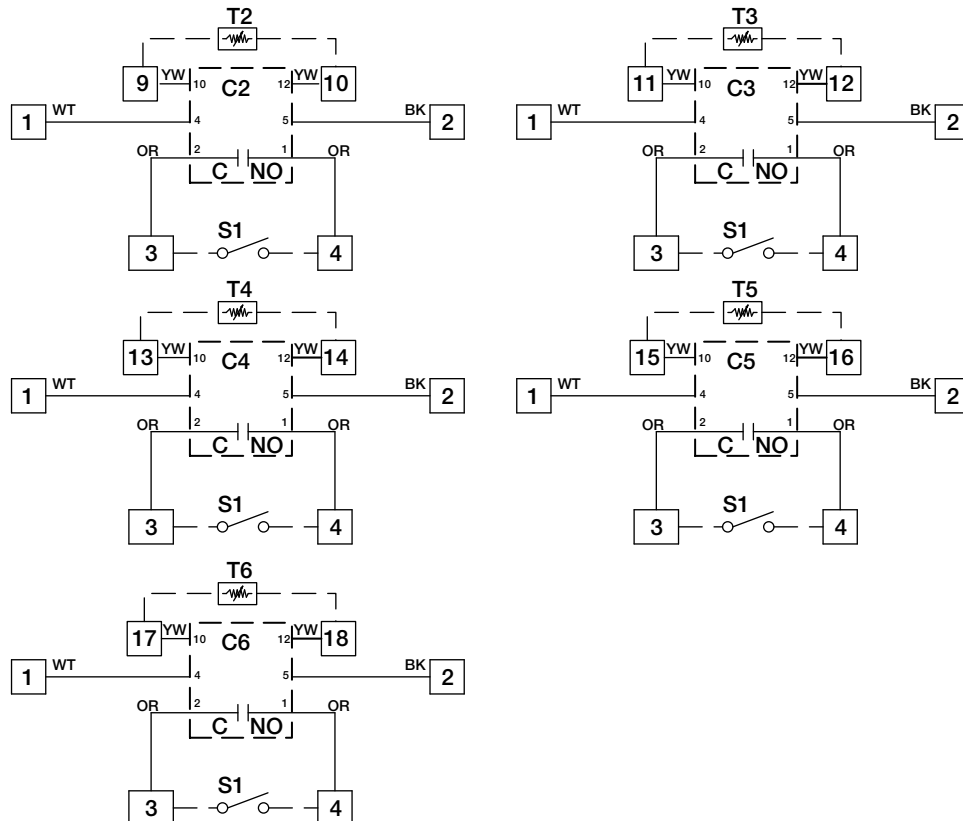



## Testing

---

1. Turn fan switch on, then off to ensure proper fan operation before cooking equipment is started. Once this is verified, testing can proceed.
2. Heat up cooking equipment with fans off. Once the duct temperature reaches the set point of the temperature controller the fans will start within 5 minutes. If the fans take more than 5 minutes to start, decrease the temperature set point by adjusting the set point on the temperature controller (see Calibration).
3. If an adjustment was made in Step 2, repeat now.
4. After verification of fan start-up, shut down cooking equipment. The fan switch should still be in the off position. Once cooking equipment has cooled below the set point plus hysteresis, the fans will shut down.

### NOTE

During testing, if fans do not start automatically in the first 10 minutes of cooking equipment activation, manually start fans to avoid accidental fire system dump due to heat build-up.

## Operation

---

1. Turn fans on and off using the fan switch. It is normal for the fans to remain running after the switch is turned off. The exhaust duct temperature controller will open after heat is no longer present under the hood and the temperature is below the set point plus hysteresis, the fans shall shut down.
2. In the event that the cooking equipment is started without turning the fans on manually, the fans will turn on automatically and remain running with the presence of heat under the hood. Once the temperature is below the set point plus hysteresis, the fans shall shut down.

## Troubleshooting

---

### ***Fans do not turn on automatically upon cooking equipment activation.***

- Check wiring to control panel or relay box
- Multiple sensors must be wired separately
- Temperature set point too high, decrease set point
- No power to fans, check breakers/starters/relays

### ***Fans do not shut off.***

- Switch must be in the off position
- Cooking equipment hot, wait for it to cool
- Temperature set point too low, increase set point
- Ensure wires connected to appropriate control circuit

### ***Fans cycle off to on when turned off.***

- Cooking equipment not cooled enough, retry in 5 minutes

### ***Fans do not turn on quick enough.***

- Decrease temperature set point

## Maintenance

---

### **Daily**

Clean the temperature sensor with cloth and degreaser. Keep clean for best performance.

### **Weekly**

Dependant on grease production and grease filter type, clean temperature sensor.

### **Seasonal**

May have to change temperature setting on the temperature controller if ambient kitchen temperatures fluctuate between summer and winter seasons.

### **Whom to call**

Contact your local manufacturer's representative.

### **What to have ready for the call**

Sales order, serial number and description of product.

Sales Order Number \_\_\_\_\_

Serial Number \_\_\_\_\_



## Frequently Asked Questions

**What temperature is the temperature controller set to from the factory?**

95° Fahrenheit.

**Will the temperature interlock automatically start/stop the fans?**

When connected properly to fan starters the temperature interlock will automatically control the fans without input from the user. However, the intended use of the temperature interlock is as back-up to manual control.

**May I connect the power going to my fan directly through the control box?**

No, the control box should only use control voltage only (24-120V), and a separate 120V power source is required to run the temperature interlock controls. Accurex recommends the use of starters sized for each fan.

**Can I use one control box for multiple hood systems?**

This can be done, however, it is not recommended. Any one of the temperature controllers would turn on all hoods running on that control box. It is better to have one hood/fan per control box, plus a significant energy savings can be obtained if one or more of the hoods is not in operation.

**Can I still turn my fan on and off?**

Yes, the temperature interlock is designed to be operated with a typical on/off switch. The fan may not turn off directly after turning the fan switch off, it will sense when the cooking operations have cooled and then turn off.

## Replacement Parts

Quantity	Part Number	Description
1	384439	Temperature Sensor (RTD) MAMAC TE-700-0-1-A
1	384440	Temperature Controller Dwyer 40T-10
1	830125	Ext, Octagon (drilled) SC55151-1/2 (380928)
1	380926	Cover, Octagon Box SC#54-C-1RACO 722
3	382859	Terminal Block, 3 pole, DIN-RAIL MT, BUS NDN3-WH
2	382858	Jumper, DIN-RAIL Terminal Block #JNDN3
1	463570	Evergreen Compression Seal, 1/4-inch, #302

## Codes and Standards Compliance

- UL 710
- National Fire Protection Association (NFPA 96)
- International Mechanical Code (IMC) 2006 Section 507.2.1.1

## Warranty

Accurex warrants this equipment to be free from defects in material and workmanship for a period of one year from the shipment date. Any units or parts which prove to be defective during the warranty period will be replaced at our option when returned to our factory, transportation prepaid. Motors are warranted by the motor manufacturer for a period of one year. Should motors furnished by Accurex prove defective during this period, they should be returned to the nearest authorized motor service station. Accurex will not be responsible for any removal or installation costs.

*As a result of our commitment to continuous improvement, Accurex reserves the right to change specifications without notice.*



P.O. Box 410 Schofield, WI 54476  
Phone: 888.333.1400 Fax: 715.241.6191  
www.accurex-systems.com