

Installation, Operation, and Maintenance Manual

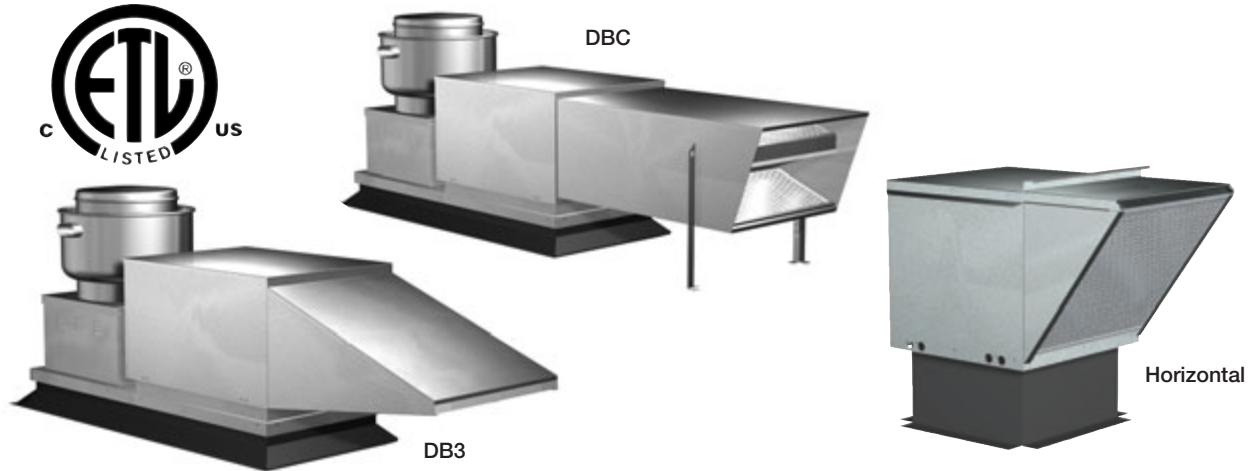

WARNING!

Disconnect all electrical power to the fan and secure to the "OFF" position prior to inspection or servicing. Failure to comply with this safety precaution could result in serious injury or death.

WARNING!

Improper installation, adjustment, alteration, service or maintenance can cause property damage, injury or death. Read the installation, operating, and maintenance instructions thoroughly before installing or servicing this equipment.

IMPORTANT!

All factory provided lifting lugs must be used when lifting any unit. Failure to comply with this safety precaution could result in property damage, serious injury or death.

Report any damaged equipment to the shipper immediately!

All units are shipped on a skid or packaged to minimize damage during shipment. The transporting carrier has the responsibility for delivering all items in their original condition as received from Accurex. The individual receiving the equipment is responsible for inspecting the unit for obvious or hidden damage, recording any damage on the bill of lading before acceptance and filing a claim (if required) with the final carrier. Some accessory items are stored inside the unit during shipping. Care must be taken during installation to prevent damage to units.

STORAGE

When a unit is not going to be in service for an extended amount of time, certain procedures should be followed to keep the unit in proper operating condition:

- Rotate fan wheel monthly
- Energize fan motor once every three months
- Store belts flat to keep them from warping and stretching
- Store unit in location without vibration
- Cover unit with tarp to protect from dirt and moisture

NOTE

Do not cover unit with a black tarp, as this will promote condensation.

NOTE

Improper storage which results in damage to the unit will void the warranty.

Please read and save these instructions for future reference. Read carefully before attempting to assemble, install, operate or maintain the unit. Failure to comply with instruction could result in personal injury and/or property damage!

Upon receiving unit, check for any damage that may have occurred during transit and report it immediately to the shipper. Also check to see that all accessory items are accounted for.

Installation: Stand Alone

Step 1 Install Curb/Equipment Support(s)

Position curb/equipment support(s) on the roof (refer to the CAPS submittal for curb/equipment support(s) location in relation to the unit). Verify that all unit supports are level, shim if necessary. Attach curb to roof and flash into place.

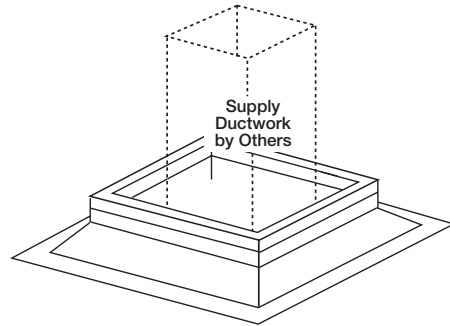

Step 2 Install Ductwork

Good duct practices should be followed for all ductwork. All ductwork should be done in accordance with SMACNA and AMCA guidelines, NFPA 96 and any local codes.

See the CAPS submittal for the recommended supply duct sizes.

The ductwork should extend far enough above the roofline to meet the supply unit once it is installed.

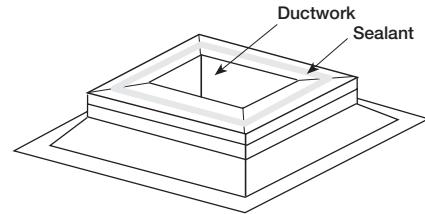

Step 3 Apply Sealant

Before installing supply unit, apply a sealant around the perimeter of the supply duct to isolate the fan and minimize vibration.

Step 4 Install Supply Unit

Use a crane and a set of spreader bars hooked to the factory lifting lugs (as shown in the diagram) to lift and center the unit on the curb.

Use self-tapping sheet metal screws to fasten unit to the curb.

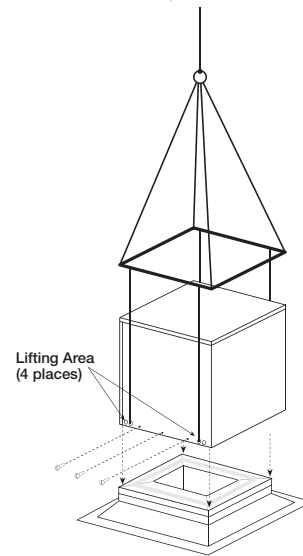

NOTE

The use of all lifting lugs and a set of spreader bars is mandatory when lifting unit.

Step 5 Assemble Weatherhood

See the reference section for weatherhood assembly instructions.

Complete Installation

Illustrations show the complete installation of a standard DB and HZ and extended DB unit.

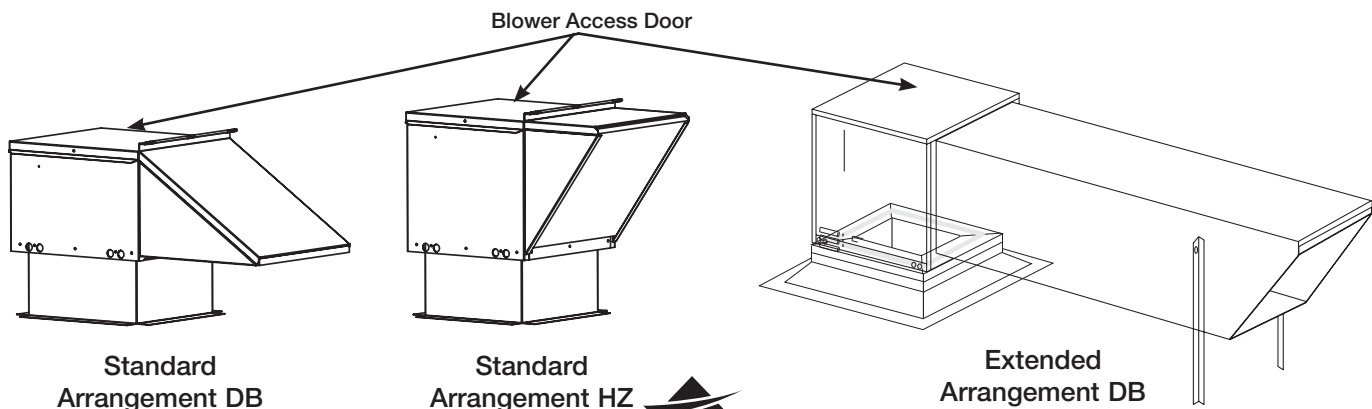

Installation: Combo Curb

Step 1 Install Curb/Equipment Support(s)

Position curb/equipment support(s) on the roof (refer to the CAPS submittal for curb/equipment support(s) location in relation to the unit). Verify that all unit supports are level, shim if necessary. Attach curb to roof and flash into place.

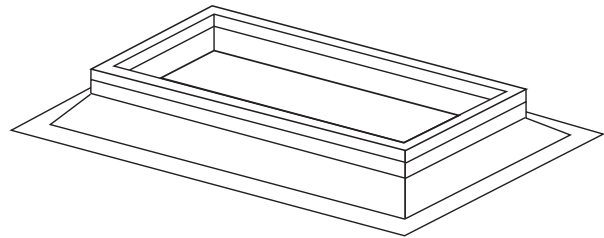

Step 2 Install Combination Curb Adaptor

Install combination curb adaptor over curb, use wood screws to lag in place. Locate extension so the tall louvered side is over the exhaust opening, as shown in illustration. Caulk extension to combination curb adaptor. Fasten extension to curb adaptor with #12 sheet metal screws (field provided).

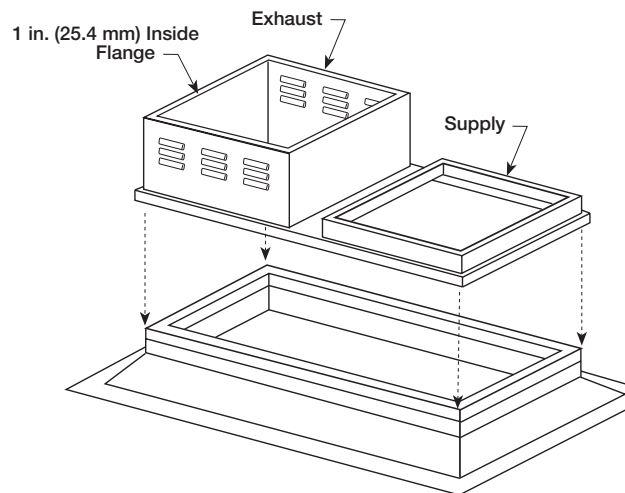

Step 3 Install Ductwork

Good duct practices should be followed for all ductwork. All ductwork should be done in accordance with SMACNA and AMCA guidelines, NFPA 96 and any local codes.

See the CAPS submittal for the recommended supply and exhaust duct sizes.

The ductwork should extend far enough above the roofline to meet the supply and exhaust units once they are installed.

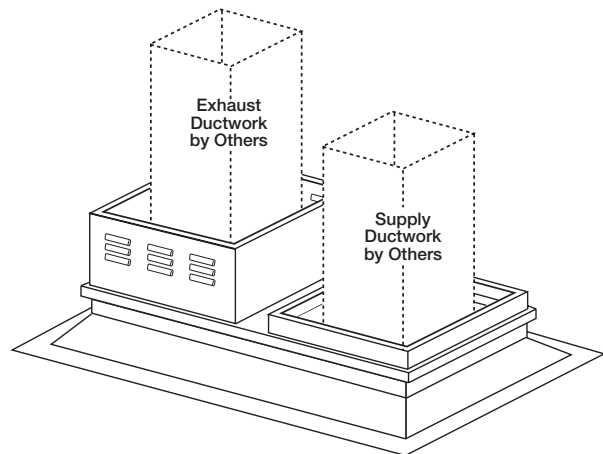

Step 4 Apply Sealant

Before installing exhaust fan and supply unit, apply a sealant around the perimeter of the exhaust and supply duct to isolate the fan and minimize vibration.

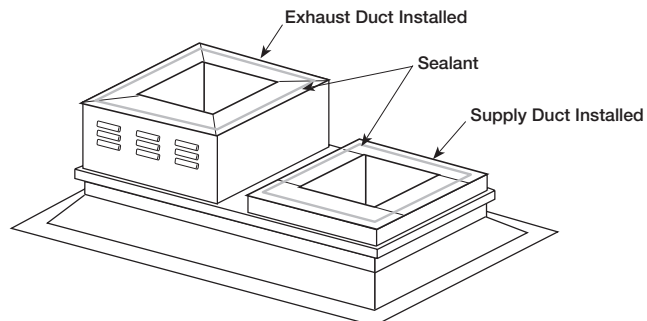

Installation: Combo Curb

Step 5 Install Exhaust Fan

Fasten exhaust fan to curb extension with self-tapping sheet metal screws.

NOTE

Installing the exhaust fan prior to the supply unit will allow for easier installation of options.

Step 6 Install Exhaust Options

Install optional Accurex hinge kit with restraining cables and grease trap with drain connection.

Step 7 Install Supply Unit

Use a crane and a set of spreader bars hooked to the factory lifting lugs (as shown in the diagram) to lift and center the unit on the curb.

Use self-tapping sheet metal screws to fasten unit to the curb.

NOTE

The use of all lifting lugs and a set of spreader bars is mandatory when lifting unit.

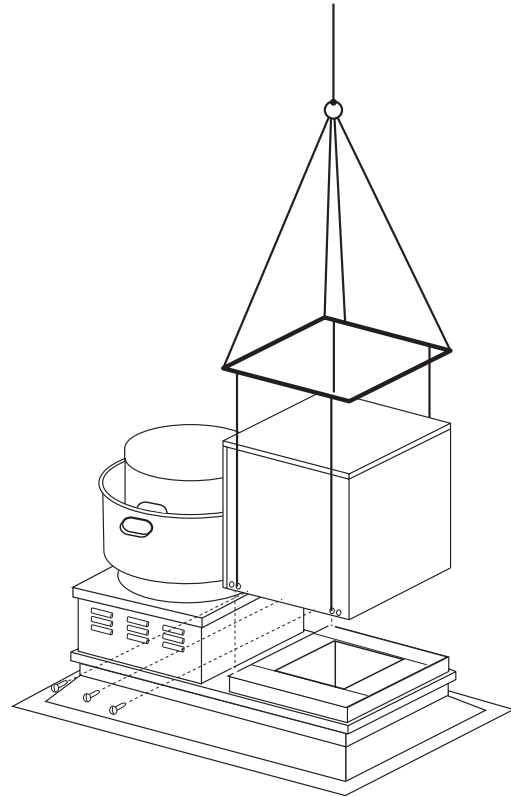

Step 8 Assemble Weatherhood

See the reference section for weatherhood assembly instructions.

Complete Installation

Illustrations show the complete installation of a DB3 and DBC unit.

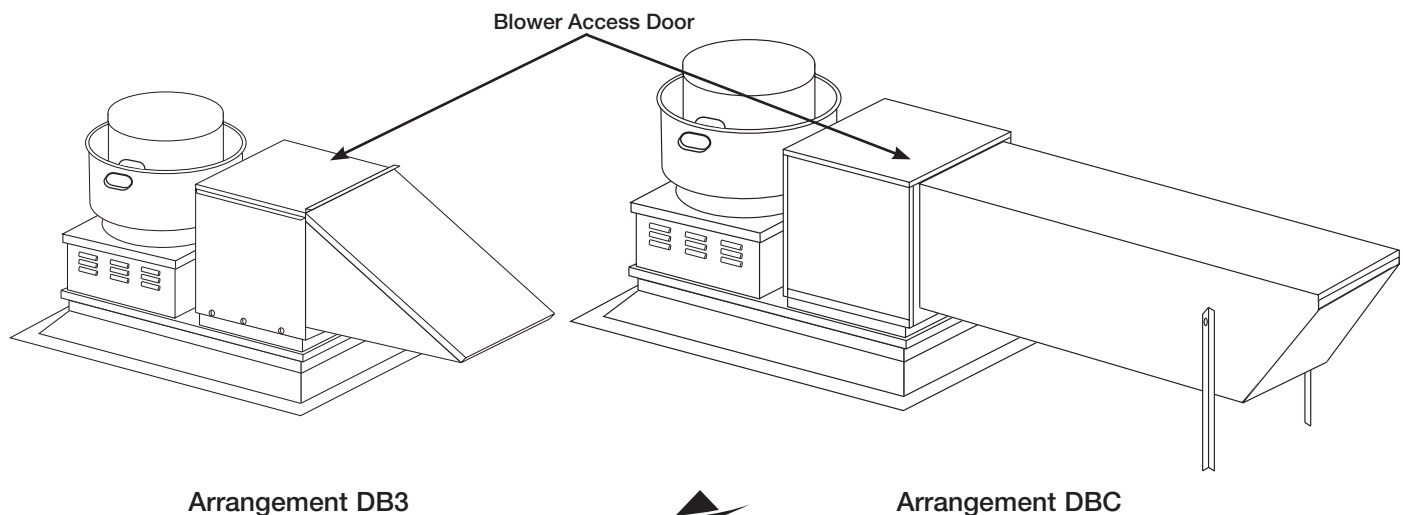

Arrangement DB3

Arrangement DBC

Installation - Electrical Wiring

IMPORTANT!

Before connecting power to the unit, understand the following instructions.

IMPORTANT!

All wiring should be done in accordance with the latest edition of the National Electrical Code ANSI/NFPA-70 and any local codes that may apply. In Canada, wiring should be done in accordance with the Canadian Electrical Code.

CAUTION!

If any of the original wire must be replaced, the replacement wire must have a temperature rating of at least 105°C.

DANGER!

High voltage electrical input is needed for this equipment. This work should be performed by a qualified electrician.

CAUTION!

Any wiring deviations may result in personal injury or property damage. Accurex is not responsible for any damage to or failure of the unit caused by incorrect final wiring.

Step 1 Determine the Size of the Main Power Lines

The unit nameplate states the unit's voltage and total amps. The main power lines to the unit should be sized accordingly.

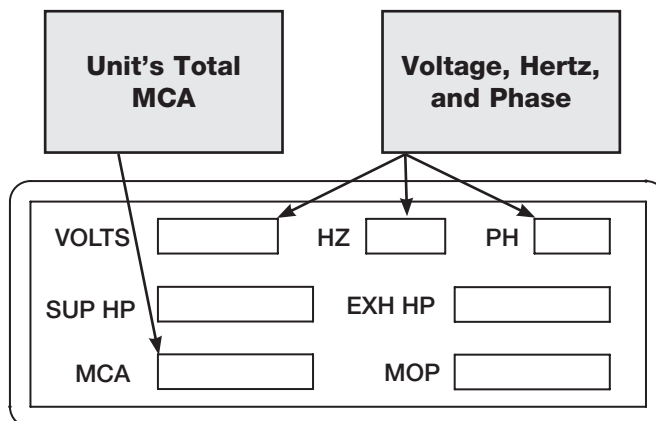

Step 2 Connect the Main Power

Connect the power line to the disconnect switch. The electrical supply must be compatible with the fan motor with regards to voltage, phase, and amperage capacity. Moreover, the electrical supply line must be properly fused and conform to local and national electrical codes. Electrical wires must be located so as not to rub on moving components.

IMPORTANT!

If fan motor is not thermally protected, remote overload protection must be installed having the adequate rating as to voltage, frequency horsepower, and full load current per phase.

Start-Up - Blower

Pre-Start-Up Check

Rotate the fan wheel by hand and make sure no parts are rubbing. Check the V-belt drive (XKSFB only) for proper alignment and tension (a guide for proper belt tension and alignment is provided in the belt maintenance section). Check fasteners, set screws and locking collars on the fan, bearings, drive (XKSFB only), motor base and accessories for tightness.

WARNING!

Disconnect and lock-out all power before performing any maintenance or service to the unit. Failure to do so could result in property damage and serious injury or death.

SPECIAL EQUIPMENT REQUIRED

Below is a list of recommended special tools that are required. Equivalent products may be used.

Description	Manufacturer-Model	Phone	Website
Voltage Meter	Fluke-23	1-800-44-FLUKE	www.fluke.com
Amperage Meter	Fluke-23	1-800-44-FLUKE	www.fluke.com
Tachometer	Monarch-Pocket Tach 100	1-800-999-3390	www.monarchinstruments.com

Step 1 Check the Voltage

Before starting the unit, compare the supplied voltage, hertz, and phase with the unit and motor nameplate information.

VOLTS	<input type="text"/>	HZ	<input type="text"/>	PH	<input type="text"/>
SUP HP	<input type="text"/>	EXH HP	<input type="text"/>		
MCA	<input type="text"/>	MOP	<input type="text"/>		

Step 2 Check the Blower Rotation

Remove the housing cover and run the blower momentarily to determine the rotation. Arrows are placed on the blower scroll to indicate the proper direction.

IMPORTANT!

If the blower is rotating in the wrong direction, the unit will move some air, but will not perform as designed. Be sure to perform a visual inspection to guarantee the correct blower rotation.

NOTE!

To reverse the rotation on three phase units, disconnect and lock-out the power, then interchange any two power leads.

NOTE!

To reverse the rotation on single phase units, disconnect and lock-out the power, then rewire the motor per the manufacturer's instructions.

Step 3 Check for Vibration

Check for unusual noise, vibration or overheating of the bearings and take corrective action.

IMPORTANT!

Excessive vibration may be experienced during the initial start-up. Left unchecked, it can cause a multitude of problems including structural and/or component failure.

IMPORTANT!

Generally, fan vibration and noise is transmitted to other parts of the building by the ductwork. To minimize this undesirable effect, the use of heavy canvas connectors is recommended.

Step 4 Motor Check

Measure the motor's voltage, amps and RPM. Compare to the specifications. Motor amps can be reduced by lowering the motor RPM or increasing system static pressure.

Step 5 Air Volume Measurement and Check

Measure the unit's air volume (CFM) and compare it with its rated air volume. If the air volume is off, adjust the belts and drives (XKSFB) or speed controller (XKSFD) until the specified air volume is reached.

NOTE!

The most accurate method for measuring the air volume is a pitot traverse method downstream of the blower. Other methods can be used but should be proven and accurate.

WARNING!

Changing the belts or drives can significantly increase the amp draw of the motor. If changes are made to the drives or belts, the amps must be checked to assure no overamping.

Maintenance

CAUTION!

Lock-out the electrical power to the unit before performing any maintenance or service.

V-Belt Drives (XKSFB only)

V-belt drives must be checked on a regular basis for wear, tension, alignment and dirt accumulation. Check the alignment by using a straight edge across both sheaves as shown to the right. Check the tension by measuring the deflection in the belt as shown to the far right.

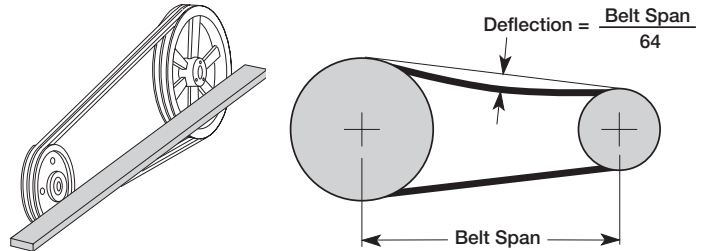

IMPORTANT!

Improper belt tension and/or misaligned sheaves lead to premature and frequent belt failures.

IMPORTANT!

Do not pry belts on or off the sheave. Loosen belt tension until belts can be removed by gently lifting them off of the sheaves.

IMPORTANT!

When replacing V-belts on multiple groove drives, all belts should be changed to provide uniform drive loading.

IMPORTANT!

Do not install new belts on worn sheaves. If the sheaves have grooves worn in them, they must be replaced before new belts are installed.

Wheels

Wheels require little attention when moving clean air. Occasionally, oil and dust may accumulate on the wheel causing imbalance. When this occurs the wheel and housing should be cleaned to assure proper operation.

Filters

Filter maintenance is generally limited to cleaning and replacement. The filters in the unit should be inspected at least every 3 months. Depending on the environment, filters could require changing or cleaning more or less often.

Aluminum mesh filters can be washed in warm soapy water.

An adhesive spray can be added to increase the filter efficiency.

Motors

Motor maintenance is generally limited to cleaning and lubrication (where applicable).

Cleaning should be limited to exterior surfaces only. Removing dust and grease build-up on the motor assures proper motor cooling.

Motors supplied with grease fittings should be greased in accordance with the manufacturer's recommendations.

IMPORTANT!

Be sure to reinstall filters with the airflow in the correct direction. An airflow direction arrow is located on the side of the filters.

IMPORTANT!

Replacement filters should be from the same manufacturer and be the same size as the original filters provided with the unit.

WARNING!

Greasing of motors is only intended when fittings are provided. Many fractional horsepower motors are permanently lubricated and will not require additional lubrication.

CAUTION!

Do not allow water or solvents to enter the motor or bearings. Under no circumstances should motors or bearings be sprayed with steam, water or solvents.

Reference

Standard HZ and DB3 Weatherhood Assembly Instructions

NOTE!

Assembly requires a $\frac{5}{16}$ inch nut runner and a caulk gun with weatherproof sealant.

NOTE!

Assembly Time: 5-10 minutes

The XKSFB/D standard HZ and DB3 weatherhoods are folded up and shipped on top of the unit.

To install:

- 1) Rotate one side up on weatherhood.
 - a) Run (1) sheet metal screw where shown to hold side in rotated position.
 - b) Rotate opposite side up on weatherhood and repeat step 1A.
- 2) Rotate assembly forward.
- 2) Screw the sides of the weatherhood to the unit. Pilot holes are provided.
- 3) Caulk all seams with an appropriate weatherproof sealant.
- 4) There are four housing sizes: H05, H08, H15, and H25. The H05 housing requires a single filter at the face of the intake hood. The H08, H15, and H25 housings require multiple filters installed at the face of the intake hood. As such, these three units require installation of an additional center track (two pieces) to support the multiple filters. The filters and center track pieces are shipped inside the XKSFB/D housing. Slide the tabbed end of each track into the slot at the bottom of the intake opening on the unit housing. Rotate the tracks up to the top outer edge of the weatherhood such that the weatherhood edge slides into the slot in the tracks.
- 5) Insert the factory provided aluminum mesh intake filter(s) into the track located in the face of the weatherhood. Filters slide in from the top. Be sure the filters are properly orientated (an airflow direction arrow is located on the side of the filters).

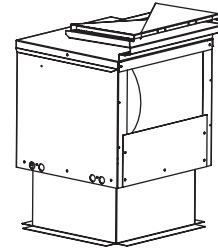

Rotate sides up, install screws. Rotate assembly forward. See step 3.

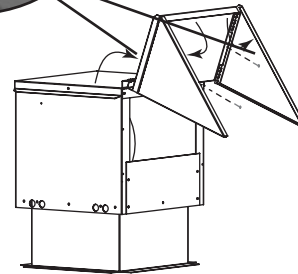

Center filter rack
(2 pieces)

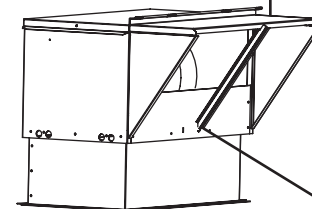

Slot in unit

Housing 08, 15, & 25
HZ

Track for
aluminum mesh
intake filters

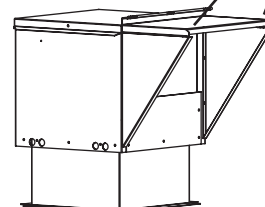

Housing 05
HZ

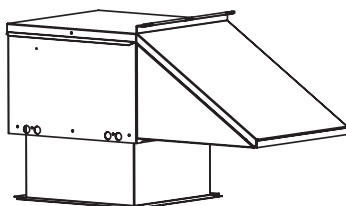

Housing 05, 08, 15, & 25
HZ

Reference

Extended 10 ft. (DBC) Weatherhood Assembly Instructions

NOTE!

Assembly requires a $\frac{5}{16}$ inch nut runner and a caulk gun with weatherproof sealant.

The XKSFB/D extended 10 ft. weatherhood is made up of up to three parts: 1) a fixed section attached to the unit, 2) a folded up section shipped on top of the fixed section, and 3) an assembled section shipped on top of the fixed section. This three part assembly applies to both the DB and HZ arrangements. To install:

- 1) Lift unit onto curb. Prior to disconnecting from crane, adjust support legs on fixed section of the extended weatherhood to appropriate height to support hood.
- 2) For housing sizes H05 and H08, rotate the assembled section of the weatherhood forward.
- 3) For housing sizes H15 and H25, rotate one side up on weatherhood.
 - a) Run (1) sheet metal screw where shown to hold side in rotated position.
 - b) Rotate opposite side up on weatherhood and repeat step 3A.
- 4) Screw the sides (and bottom on Housing 05 & 08) of the weatherhood to the unit. Pilot holes are provided.
- 5) Caulk all seams with an appropriate weatherproof sealant.
- 6) There are four housing sizes: H05, H08, H15, and H25. The H05 housing requires a single filter at the face of the intake hood. The H08, H15, and H25 housings require multiple filters installed at the face of the intake hood. As such, these three units require installation of an additional center track (two pieces) to support the multiple filters. The filters and center track pieces are shipped inside the XKSFB/D housing. Slide the tabbed end of each track into the slot at the bottom of the intake opening. Rotate the tracks up to the top outer edge of the weatherhood such that the weatherhood edge slides into the slot in the tracks.
- 7) Insert the factory provided 1-inch aluminum mesh intake filter(s) into the track located in the face of the weatherhood. Filters slide in from the top. Be sure the filters are properly orientated (an airflow direction arrow is located on the side of the filters).

NOTE: Housing 15 & 25 have no bottom section to the weatherhood.

NOTE!

Assembly Time: 5-10 minutes

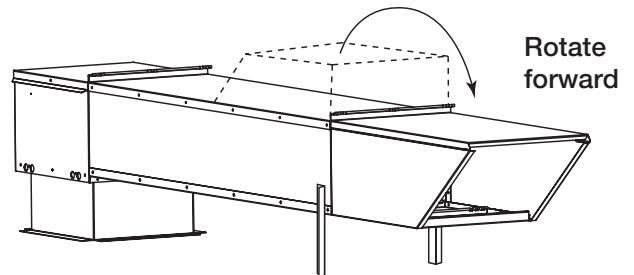

Weatherhood Installation for Housing 05 & 08

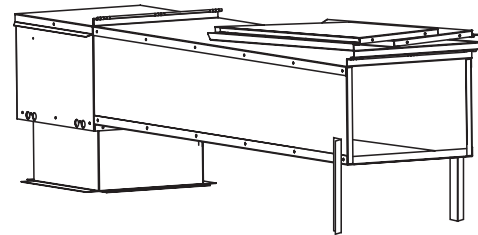

Housing 15 & 25

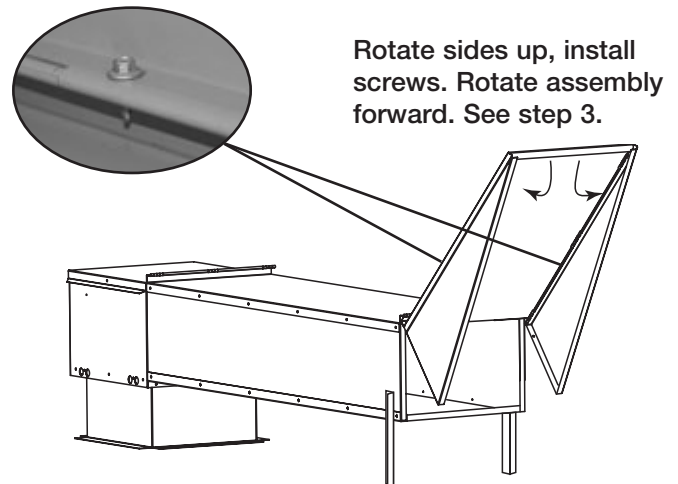

Housing 15 & 25

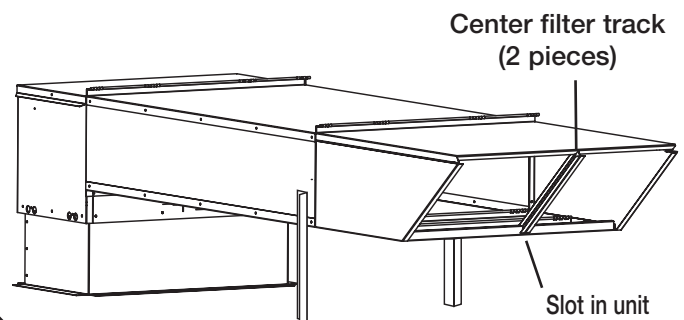

Housing 08, 15, & 25

WARRANTY

Accurex warrants this equipment to be free from defects in material and workmanship for a period of one year from the date of shipment. Any units or parts which prove to be defective during the warranty period will be replaced at our option when returned to our factory, transportation prepaid. Motors are warranted by the motor manufacturer for a period of one year. Should motors furnished by Accurex prove defective during this period, they should be returned to the nearest authorized motor service station. Accurex will not be responsible for any removal or installation costs.

As a result of our commitment to continuous improvement, Accurex reserves the right to change specifications without notice.



P.O. Box 410 Schofield, WI 54476
Phone: 800.333.1400 Fax: 715.241.6171
www.accurex-systems.com

*IOM XKSFB/XKSFD Rev. 2 April 2012
Copyright © 2012 Accurex*