

## Installation, Operation, and Maintenance Manual

### Component Identification

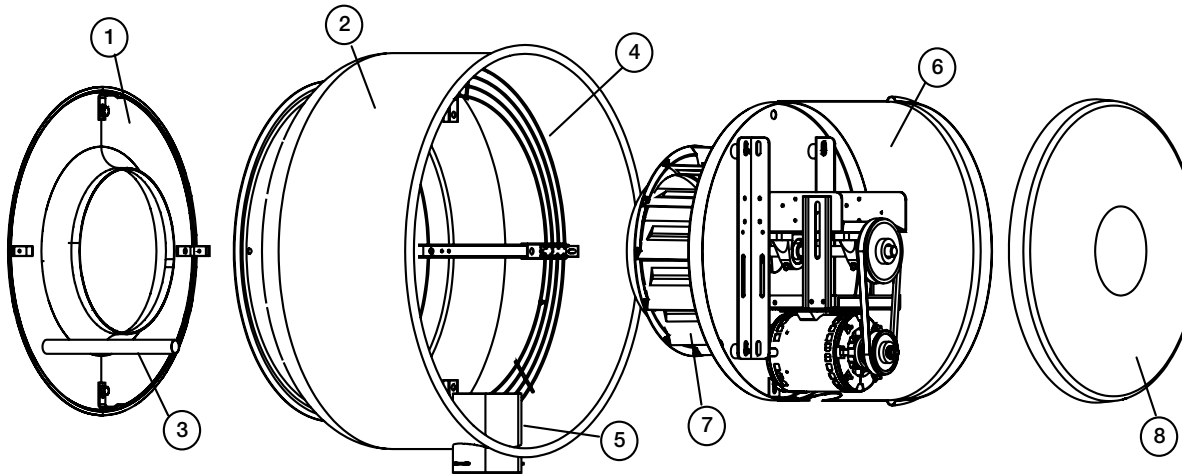

- 1 MOUNTING PLATE
- 2 WINDBAND
- 3 ELECTRICAL CHASE
- 4 BIRDSCREEN
- 5 BREATHER TUBE
- 6 MOTOR COMPARTMENT
- 7 WHEEL
- 8 COVER

### Dimensional Data

#### XSED - Direct Drive

Model	E	F**	G	Wall	Damper	Damper Frame Size	Mtg. Bolt Circle
XSED-060,065,070,075	18 <sup>3</sup> / <sub>8</sub>	13 <sup>1</sup> / <sub>2</sub>	14 <sup>3</sup> / <sub>4</sub>	8 <sup>1</sup> / <sub>2</sub> x8 <sup>1</sup> / <sub>2</sub>	8x8	10x10	11 <sup>3</sup> / <sub>4</sub>
XSED-080,085,090 XSED-095	21	13 <sup>3</sup> / <sub>8</sub> 15 <sup>1</sup> / <sub>4</sub>	17 <sup>7</sup> / <sub>8</sub>	10 <sup>1</sup> / <sub>2</sub> x10 <sup>1</sup> / <sub>2</sub>	10x10	12x12	15
XSED-098,101,121,131	24 <sup>7</sup> / <sub>8</sub>	23 <sup>3</sup> / <sub>4</sub>	19 <sup>3</sup> / <sub>4</sub>	12 <sup>1</sup> / <sub>2</sub> x12 <sup>1</sup> / <sub>2</sub>	12x12	14x14	16 <sup>7</sup> / <sub>8</sub>
XSED-141,161	28 <sup>7</sup> / <sub>8</sub>	24 <sup>3</sup> / <sub>4</sub>	22 <sup>1</sup> / <sub>2</sub>	15 <sup>1</sup> / <sub>2</sub> x15 <sup>1</sup> / <sub>2</sub>	15x15	17x17	19 <sup>5</sup> / <sub>8</sub>

\*NOTE: 2 inches minimum, 8 inches when motorized option is required  
\*\*May vary depending on motor size

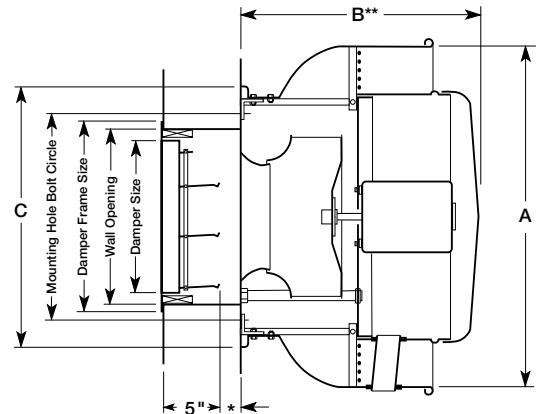

#### XSEB - Belt Drive

Model	E	F**	G	Wall Opening	Damper Size	Damper Frame Size	Mtg. Bolt Circle
XSEB-098,101,101HP,121,131	24 <sup>7</sup> / <sub>8</sub>	23 <sup>3</sup> / <sub>4</sub>	19 <sup>3</sup> / <sub>4</sub>	12 <sup>1</sup> / <sub>2</sub> x12 <sup>1</sup> / <sub>2</sub>	12x12	14x14	16 <sup>7</sup> / <sub>8</sub>
XSEB-141,141HP,161,161HP	28 <sup>7</sup> / <sub>8</sub>	24 <sup>3</sup> / <sub>4</sub>	22 <sup>1</sup> / <sub>2</sub>	15 <sup>1</sup> / <sub>2</sub> x15 <sup>1</sup> / <sub>2</sub>	15x15	17x17	19 <sup>5</sup> / <sub>8</sub>
XSEB-180,180HP,200,200HP	35 <sup>3</sup> / <sub>8</sub>	28 <sup>5</sup> / <sub>8</sub>	27 <sup>3</sup> / <sub>4</sub>	17 <sup>1</sup> / <sub>2</sub> x17 <sup>1</sup> / <sub>2</sub>	17 x17	19x19	25
XSEB-220,220HP,240,240HP	42 <sup>25</sup> / <sub>32</sub>	33 <sup>7</sup> / <sub>8</sub>	31 <sup>1</sup> / <sub>4</sub>	20 <sup>1</sup> / <sub>2</sub> x20 <sup>1</sup> / <sub>2</sub>	20x20	22x22	28 <sup>3</sup> / <sub>8</sub>
XSEB-300,300HP	50	36	38 <sup>3</sup> / <sub>8</sub>	25 <sup>1</sup> / <sub>2</sub> x25 <sup>1</sup> / <sub>2</sub>	25 x25	27x27	35 <sup>27</sup> / <sub>32</sub>

\*NOTE: 2 inches minimum  
7 inches when motorized option is required

\*\*May vary depending on motor size

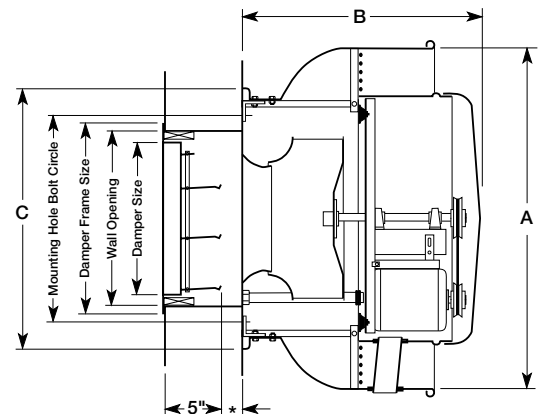

Please read and save these instructions for future reference. Read carefully before attempting to assemble, install, operate or maintain the unit. Failure to comply with instruction could result in personal injury and/or property damage!

Upon receiving unit, check for any damage that may have occurred during transit and report it immediately to the shipper. Also check to see that all accessory items are accounted for.

# Installation

Upon receiving unit, check for any damage and report it immediately to the shipper. Also check to see that all accessory items are accounted for.

These fans exhaust directly away from the building, therefore their location and placement should be analyzed. Proximity to nearby buildings and people must be considered.

Access to the motor compartment is accomplished by removing the screws from the cover. The cover can then be removed and placed on a flat surface in an area protected from strong winds.

The motor's amperage and voltage rating must be checked for compatibility to the supply voltage prior to final electrical connection. For NFPA - restaurant applications, the electrical supply must enter the motor compartment through the breather tube. For other non-flammable applications the electrical supply can be routed through the conduit chase between the curb cap and the bottom of the motor compartment. **Consult local code authorities for your specific requirements.**

## IMPORTANT: UL/cUL 762 Installations are for Restaurant Applications.

XSEB (all) and XSED (A, B, and C motor RPMs ) are the only fans approved for this installation. All must include the suffix "G".

All fans must be installed per NFPA 96 and meet all local code requirements. In addition, the maximum operating temperature at the fan must not exceed 375 degrees F.

### STEP 1

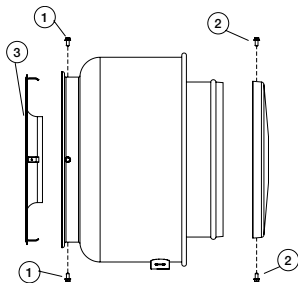

Remove mounting plate from unit by removing the fasteners shown above marked by (1). Remove motor compartment cover by removing fasteners marked by (2).

### STEP 2

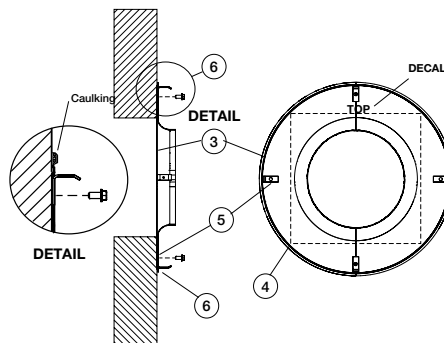

Locate the mounting plate (3) at the desired position and check to avoid unit clearance problems. Cut the wall opening (4) as shown based upon dimensions obtained from the Dimensional Data Section. Locate top of mounting plate (decals) and attach to the wall construction. The fasteners must pass through the holes provided in the mounting angle clips (5) on the mounting plate (3). For uneven surfaces, shims may be required. Sealant or caulking should be applied in the groove (6) formed by the mounting plate and the wall to prevent moisture leakage into the building.

### STEP 3

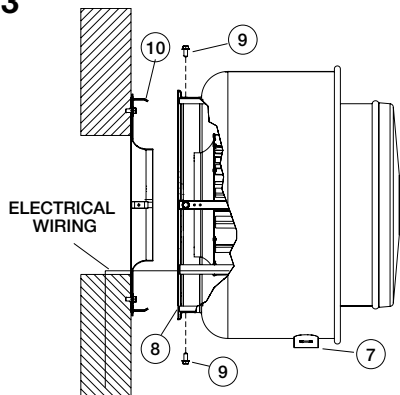

Once the mounting plate has been attached to the wall, the unit can be installed. The unit should be aligned with the breather tube (7) pointing down. The electrical chase should be guided through the hole in the motor compartment. The horizontal support channels (8) should slide over the mounting angle clips (10) on the mounting plate until the holes in the windband and clips are aligned. Replace fasteners (9) and tighten. Wiring now can be done. Consult local code authorities for your specific requirements.

### STEP 4 XSED/XSEB Models 098 - 300

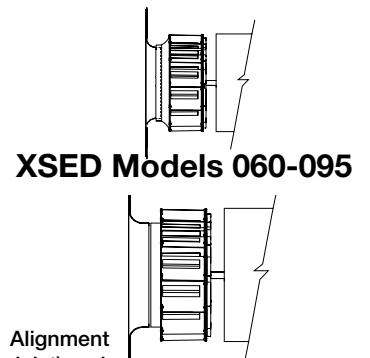
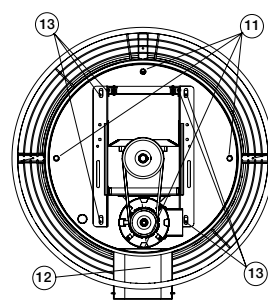

During shipping, wheel position may shift. Alignment should be as shown above (centered in the inlet) and can be accomplished by loosening the fasteners (11) located in the motor compartment. For belt drive units, additional vertical alignment can be accomplished by loosening the four fasteners on the drive frame support angles, and the 2 fasteners that hold the L-brackets to the support angles on top (13). Also, horizontal alignment can be made by loosening the bearings from the bearing plate.

Removal of the entire power pack (motor, drives and wheel) for maintenance or cleaning can be accomplished by removing the breather tube (12) and fasteners (11).

## Pre-Starting Checks

Check all fasteners for tightness. The wheel should rotate freely and be aligned as shown in Fig. 1. Wheel position is preset and the unit is test run at the factory. Movement may occur during shipment, and realignment may be necessary. Centering can be accomplished by loosening the bolts holding the drive frame to the shock mounts and repositioning the drive frame. Wheel and inlet cone overlap can be adjusted by loosening the set screws in the wheel and moving the wheel to the desired position.

### WHEEL OVERLAP DIMENSIONS

MODEL	G	H
060-095	-	3/32 in.
098-161	1/4 in.	-
180-300	1/2 in.	-

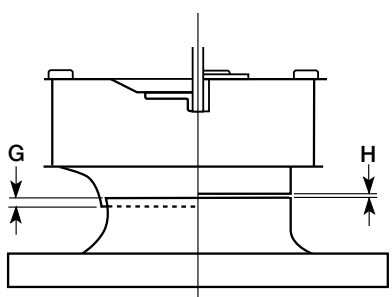

Fig. 1

### WHEEL ROTATION

All XSED/XSEB fans have a clockwise wheel rotation when viewed from top of fan.

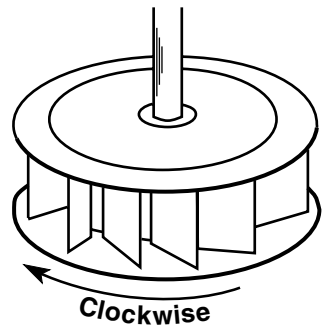

Fig. 2

Direction of wheel rotation is critical. Reversed rotation will result in poor air performance, motor overloading and possible burnout. Check wheel rotation (viewing from the shaft side) by momentarily energizing the unit. Rotation should be clockwise as shown in Fig. 2 and correspond to the rotation decal on the unit.

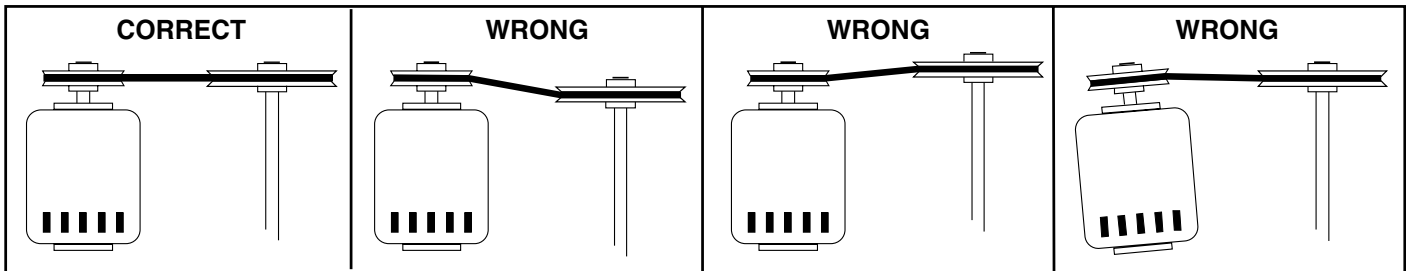
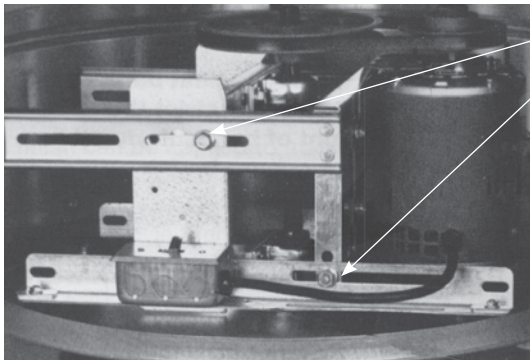

Fig. 3

If adjustments are made, it is very important to check the pulleys for proper alignment. Misaligned pulleys lead to excessive belt wear, vibration, noise and power loss. (See Fig. 3 )

For all XSEB units belt tension can be adjusted by loosening four fasteners (marked "R") on the drive frame. The motor plate slides on the slotted adjusting arms and drive frame angles in the same manner (see Fig. 4). Belt tension should be adjusted to allow 1/64" of deflection per inch of belt span. For example, a 15" belt span should have 15/64" (or about 1/4") of deflection with moderate thumb pressure at mid-point between pulleys. (See Fig. 5). Overtightening will cause excessive bearing wear and noise. Too little tension will cause slippage at startup and uneven wear.



NOTE:  
Identical fasteners  
on opposing side

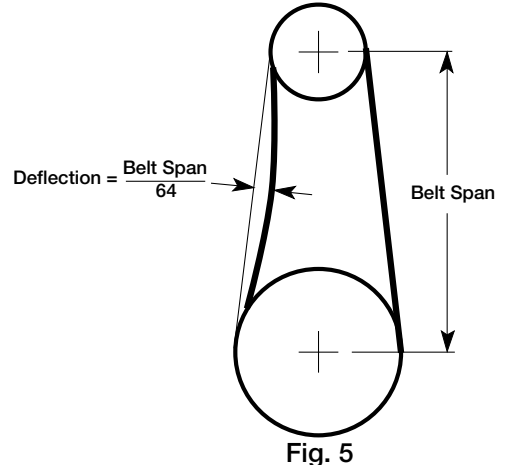

Deflection =  $\frac{\text{Belt Span}}{64}$

Fig. 4

Fig. 5

The adjustable motor pulley is factory set for the RPM specified. Speed can be increased by closing or decreased by opening the adjustable motor sheave. Two groove variable pitch pulleys must be adjusted an equal number of turns open or closed. Any increase in speed represents a substantial increase in the horsepower required by a unit. Motor amperage should always be checked to avoid serious damage to the motor when speed is varied.

## MAINTENANCE

Belts tend to stretch after a period of time. They should be checked periodically for wear and tightness. When replacing belts, use the same type as supplied with the unit. Matched belts should always be used on units with multigroove pulleys. For belt replacement, loosen the tensioning device far enough to allow removal of the belt by hand. Do not force belts on or off. This may cause cords to break, leading to premature belt failure. Once installed, adjust belts as shown in "Pre-Starting Checks."

Shaft bearings can be classified in two groups: relubricating and non-relubricating. All bearings on standard Model XSEB fans are factory lubricated and require no further lubrication under normal use (between -20°F and 180°F in a relatively clean environment). Units installed in hot, humid or dirty locations should be equipped with special bearings. These bearings will require frequent lubrication. Caution should be employed to prevent overpacking or contamination. Grease fittings should be wiped clean. The unit should be in operation while lubricating. Extreme care should be used around moving parts. Grease should be pumped in very slowly until a slight bead forms around the seal. A high grade lithium base grease is recommended.

Motor maintenance is generally limited to cleaning and lubrication (where applicable). Cleaning should be limited to exterior surfaces only. Removing dust buildup on motor housing ensures proper motor cooling. Greasing of motors is only intended when fittings are provided. Many fractional motors are permanently lubricated and should not be lubricated further. Motors supplied with grease fittings should be greased in accordance with manufacturers' recommendations. Where motor temperatures do not exceed 104°F (40°C), the grease should be replaced after 2000 hours of running time as a general rule.

Wheels require very little attention when moving clean air. Occasionally, oil and dust may accumulate causing imbalance. When this occurs, the wheel and housing should be cleaned to ensure smooth and safe operation.

The unit should be made non-functional when cleaning the wheel or housing (fuses removed, disconnect locked off, etc.).

All fasteners should be checked for tightness each time maintenance checks are performed prior to restarting unit.

A proper maintenance program will help these units deliver years of dependable service.

## TROUBLESHOOTING

PROBLEM	CAUSE	CORRECTIVE ACTION
<b>REDUCED AIRFLOW</b>	System resistance too high	Check system: Proper operation of backdraft or control dampers, obstruction in ductwork, etc.
	Unit running backwards	Correct as shown in Fig. 2
	Excessive dirt buildup on wheels	Clean wheel
	Improper wheel alignment	Center wheel on inlets
<b>EXCESSIVE NOISE OR VIBRATION</b>	Bad bearings	Replace
	Belts too tight or too loose	Refer to Fig. 5 and adjust tension
	Wheel improperly aligned and rubbing	Center wheel on inlets. See Fig. 1
	Loose drive or motor pulleys	Align and tighten. See "Pre-Starting Checks"
	Foreign objects in wheel or housing	Remove objects, check for damage or unbalance
	Unbalance of wheel caused by excessive dirt and grease buildup	Remove buildup

### NOTE

Before taking any corrective action, make certain unit is not capable of operation during repairs.

## WARRANTY

Accurex warrants this equipment to be free from defects in material and workmanship for a period of one year from the date of purchase. Any units or parts which prove to be defective during the warranty period will be replaced at our option when returned to our factory, transportation prepaid. Motors are warranted by the motor manufacturer for a period of one year. Should motors furnished by Accurex prove defective during this period, they should be returned to the nearest authorized motor service station. Accurex will not be responsible for any removal or installation costs.

*As a result of our commitment to continuous improvement, Accurex reserves the right to change specifications without notice.*

