

Installation, Operation, and Maintenance Manual

When lifting unit on to roof, use either the (4) lifting points on the drive frame or the (2) lifting points on the bearing plate if present. Refer to Fig. 1 for lifting points. Access to the drive frame is accomplished by removing the screws pointed out in Fig. 2 and Fig. 3. The cover can then be removed and placed on a flat surface in an area protected from strong winds. Move fan to desired location using lifting points and fasten securely through mounting holes in base. Shims may be necessary depending upon roofing material thickness. For model dimensions refer to the diagram and Fig. 4 on page 2.

The motor's amperage and voltage rating must be checked for compatibility to the supply voltage prior to final electrical connection. For NFPA - restaurant XRUB applications, the electrical supply must enter the motor compartment through the breather tube. For other non-flammable applications the electrical supply can be routed through the conduit chase between the curb cap and the bottom of the motor compartment. **Consult local code authorities for your specific requirements.**

A drain trough is provided on all XRUB fans for single-point drainage of water and residue. Some means for collection of this residue must be provided, either a container directly under the trough or use of an adapter and pipe to carry the residue to a remote collection point. An optional grease trap with water separator baffles is available from your Accurex representative.

Lifting

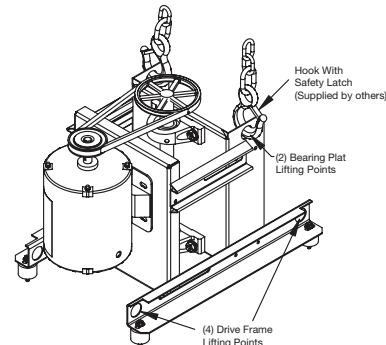

Fig. 1

Installations

Recommended General Ventilation Installation

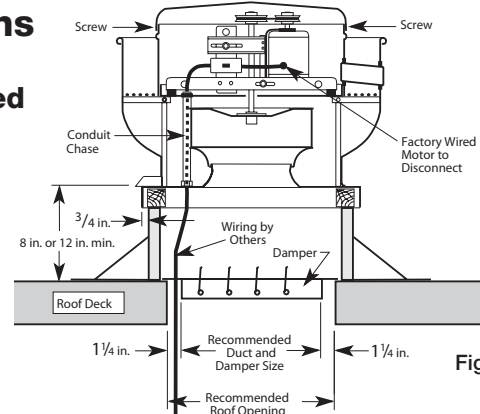

Fig. 2

Recommended Commerical Kitchen Installation

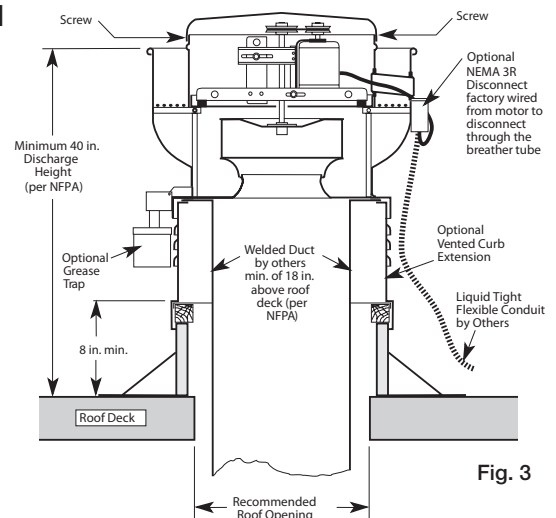

Fig. 3

Please read and save these instructions for future reference. Read carefully before attempting to assemble, install, operate or maintain the unit. Failure to comply with instruction could result in personal injury and/or property damage!

Upon receiving unit, check for any damage that may have occurred during transit and report it immediately to the shipper. Also check to see that all accessory items are accounted for.

Dimensional Data

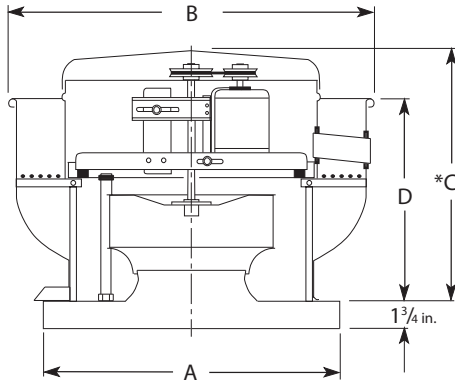

Fig. 4

All dimensions are in inches.

*May vary depending on motor size.

Dimension "A" is the inside dimension of the curb cap. The roof curb should be 1 1/2 inch less than the curb cap to allow for roofing and flashing.

Model XRUB	A	B	C	D	Shaft Bearings	Damper Size	Roof Opening	Approx. Unit Weight
098, 101, 101HP, 121, 131	19	24 ⁷ / ₈	28 ¹ / ₄	17 ³ / ₈	3/4	12 x 12	14 ¹ / ₂ x 14 ¹ / ₂	66
141, 141HP, 161, 161HP, 161XP	22	28 ⁷ / ₈	29 ³ / ₄	19 ³ / ₈	3/4	16 x 16	18 ¹ / ₂ x 18 ¹ / ₂	87
180	30	35 ⁵ / ₈	28 ⁵ / ₈	21	3/4	18 x 18	20 ¹ / ₂ x 20 ¹ / ₂	126
180HP	30	35 ⁵ / ₈	28 ⁵ / ₈	21	1	18 x 18	20 ¹ / ₂ x 20 ¹ / ₂	126
200	30	35 ⁵ / ₈	28 ⁵ / ₈	21	3/4	18 x 18	20 ¹ / ₂ x 20 ¹ / ₂	142
200HP	30	35 ⁵ / ₈	28 ⁵ / ₈	21	1	18 x 18	20 ¹ / ₂ x 20 ¹ / ₂	142
220, 220HP	34	42 ³ / ₄	33 ³ / ₈	25 ¹ / ₂	1	24 x 24	26 ¹ / ₂ x 26 ¹ / ₂	174
240, 240HP, 240XP	34	42 ³ / ₄	33 ³ / ₈	25 ¹ / ₂	1	24 x 24	26 ¹ / ₂ x 26 ¹ / ₂	175
300, 300HP, 300XP	40	50	36	29	1	30 x 30	32 ¹ / ₂ x 32 ¹ / ₂	313
360, 360HP, 360XP	46	58 ⁵ / ₈	39 ¹ / ₈	29 ³ / ₈	1 ¹ / ₄	36 x 36	38 ¹ / ₂ x 38 ¹ / ₂	440
420	52	65 ³ / ₈	44 ³ / ₄	35 ¹ / ₄	1 ¹ / ₄	42 x 42	44 ¹ / ₂ x 44 ¹ / ₂	578
480	58	74 ³ / ₁₆	48 ¹ / ₈	36	1 ¹ / ₂	48 x 48	50 ¹ / ₂ x 50 ¹ / ₂	675

Pre-Starting Checks

Check all fasteners for tightness. The wheel should rotate freely and be aligned as shown in Fig. 5. Wheel position is preset and the unit is test run at the factory. Movement may occur during shipment, and realignment may be necessary.

Centering can be accomplished by loosening the bolts holding the drive frame to the shock mounts and repositioning the drive frame. Wheel and inlet cone overlap can be adjusted by loosening the set screws in the wheel and moving the wheel to the desired position.

Wheel Overlap Dimensions

MODEL	G	H
098	-	3/32 in.
101-161	1/4 in.	-
180-300	1/2 in.	-
360-480	3/4 in.	-

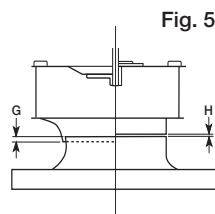

Fig. 5

Wheel Rotation

All XRUB fans have CW wheel rotation when viewed from top of fan.

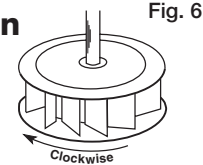

Fig. 6

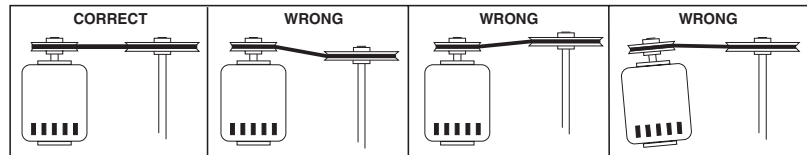

Fig. 7

Direction of wheel rotation is critical. Reversed rotation will result in poor air performance, motor overloading and possible burnout. Check wheel rotation (viewing from the shaft side) by momentarily energizing the unit. Rotation should be clockwise (CW) as shown in Fig. 6 and correspond to the rotation decal on the unit.

If adjustments are made, it is very important to check the pulleys for proper alignment. Misaligned pulleys lead to excessive belt wear, vibration, noise and power loss. Refer to Fig. 7. For all XRUB units belt tension can be adjusted by loosening four fasteners on the drive frame pointed out in Fig. 8. The motor plate slides on the slotted adjusting arms and drive frame angles in the same manner. Belt tension should be

adjusted to allow 1/64 inch of deflection per inch of belt span. For example, a 15 inch belt span should have 15/64 inch (or about 1/4 inch) of deflection with moderate thumb pressure at mid-point between pulleys. Refer to Fig. 6. Overtightening will cause excessive bearing wear and noise. Too little tension will cause slippage at startup and uneven wear.

The adjustable motor pulley is factory set for the RPM specified. Speed can be increased by closing or decreased by opening the adjustable motor sheave. Two groove variable pitch pulleys must be adjusted an equal number of turns open or closed. Any increase in speed represents a substantial increase in the horsepower required by a unit. Motor amperage should always be checked to avoid serious damage to the motor when speed is varied.

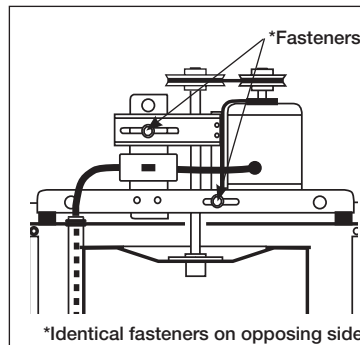

Fig. 8

*Identical fasteners on opposing side.

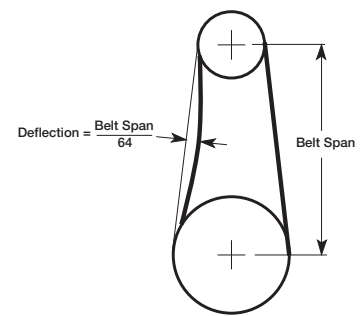

Fig. 9

Maintenance

Belts tend to stretch after a period of time. They should be checked periodically for wear and tightness. When replacing belts, use the same type as supplied with the unit. Matched belts should always be used on units with multigroove pulleys. For belt replacement, loosen the tensioning device far enough to allow removal of the belt by hand. Do not force belts on or off. This may cause cords to break, leading to premature belt failure. Once installed, adjust belts as shown in “Pre-Starting Checks.”

Shaft bearings can be classified in two groups: relubricating and non-relubricating. All bearings on standard Model XRUB fans are factory lubricated and require no further lubrication under normal use (between -20°F and 180°F in a relatively clean environment). Units installed in hot, humid or dirty locations should be equipped with special bearings. These bearings will require frequent lubrication. Caution should be employed to prevent overpacking or contamination. Grease fittings should be wiped clean. The unit should be in operation while lubricating. Extreme care should be used around moving parts. Grease should be pumped in very slowly until a slight bead forms around the seal. A high grade lithium base grease is recommended.

Motor maintenance is generally limited to cleaning and lubrication (where applicable). Cleaning should be limited to exterior surfaces only. Removing dust buildup on motor housing ensures proper motor cooling. Greasing of motors is only intended when fittings are provided. Many fractional motors are permanently lubricated and should not be lubricated further. Motors supplied with grease fittings should be greased in accordance with manufacturers’ recommendations. Where motor temperatures do not exceed 104°F (40°C), the grease should be replaced after 2000 hours of running time as a general rule.

Wheels require very little attention when moving clean air. Occasionally, oil and dust may accumulate causing imbalance. When this occurs, the wheel and housing should be cleaned to ensure smooth and safe operation.

The unit should be made non functional when cleaning the wheel or housing (fuses removed, disconnect locked off, etc.).

All fasteners should be checked for tightness each time maintenance checks are performed prior to restarting unit.

A proper maintenance program will help these units deliver years of dependable service.

Troubleshooting

PROBLEM	CAUSE	CORRECTIVE ACTION
REDUCED AIRFLOW	System resistance too high	Check system: Proper operation of backdraft or control dampers, obstruction in ductwork, etc.
	Unit running backwards	Correct as shown in Fig. 6.
	Excessive dirt buildup on wheels	Clean wheel.
	Improper wheel alignment	Center wheel on inlets.
EXCESSIVE NOISE OR VIBRATION	Bad bearings	Replace.
	Belts too tight or too loose	Refer to Fig. 9 and adjust tension.
	Wheel improperly aligned and rubbing	Center wheel on inlets. See Fig. 5.
	Loose drive or motor pulleys	Align and tighten. See “Pre-Starting Checks”, page 2.
	Foreign objects in wheel or housing	Remove objects, check for damage or unbalance.
	Unbalance of wheel caused by excessive dirt and grease buildup	Remove buildup.

NOTE: Before taking any corrective action, make certain unit is not capable of operation during repairs.

PARTS LIST

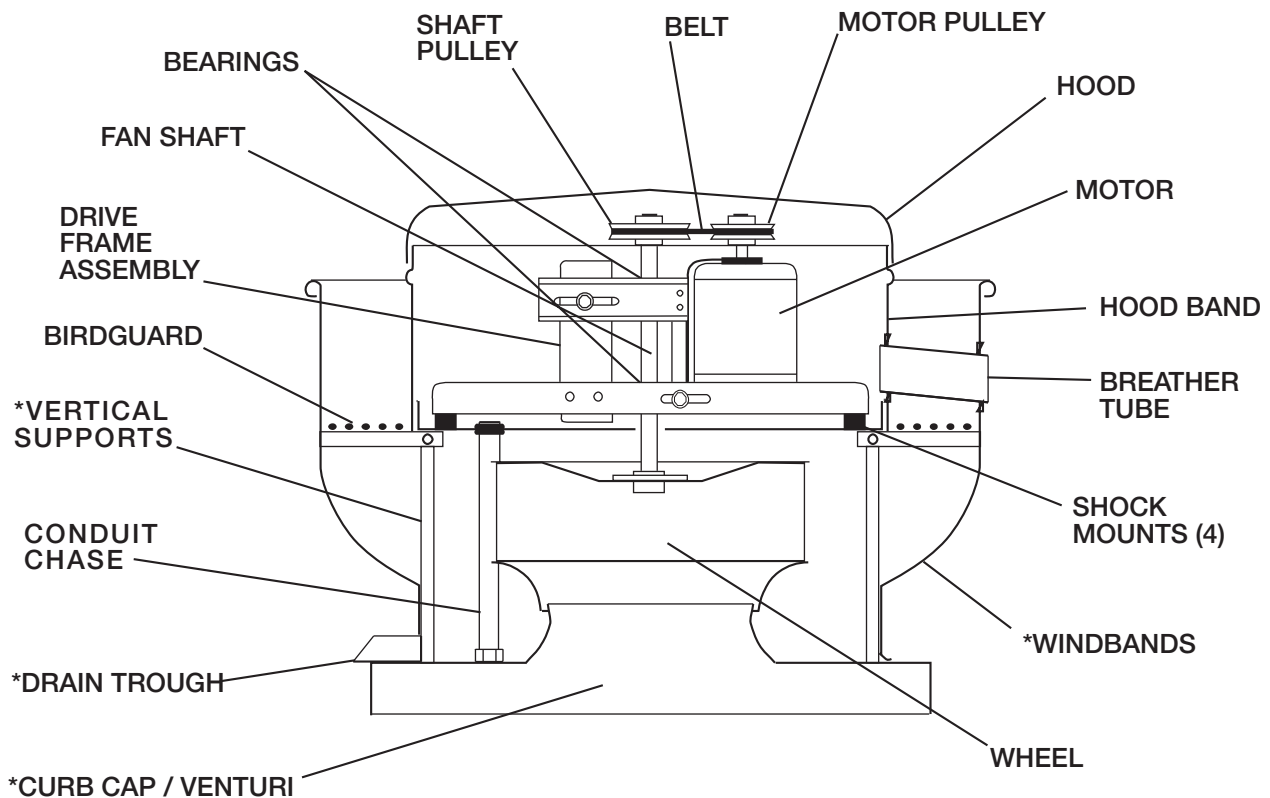

* For replacement, the windband, vertical supports, drain trough and curb cap/venturi come as one complete assembly.

NOTE

Each fan bears a manufacturer's nameplate with model number and serial number embossed. This information will assist the local Accurex representative and the factory in providing service and replacement parts.

WARRANTY

Accurex warrants this equipment to be free from defects in material and workmanship for a period of one year from the date of purchase. Any units or parts which prove to be defective during the warranty period will be replaced at our option when returned to our factory, transportation prepaid. Motors are warranted by the motor manufacturer for a period of one year. Should motors furnished by Accurex prove defective during this period, they should be returned to the nearest authorized motor service station. Accurex will not be responsible for any removal or installation costs.

As a result of our commitment to continuous improvement, Accurex reserves the right to change specifications without notice.



P.O. Box 410 Schofield, WI 54476
Phone: 800.333.1400 Fax: 715.241.6191
www.accurex-systems.com

*IOM XRUB Rev. 1 June 2007
Copyright © 2007 Accurex*